

HPR-02. Self-regulating pump for open loop operation.

Linde Hydraulics

Linde

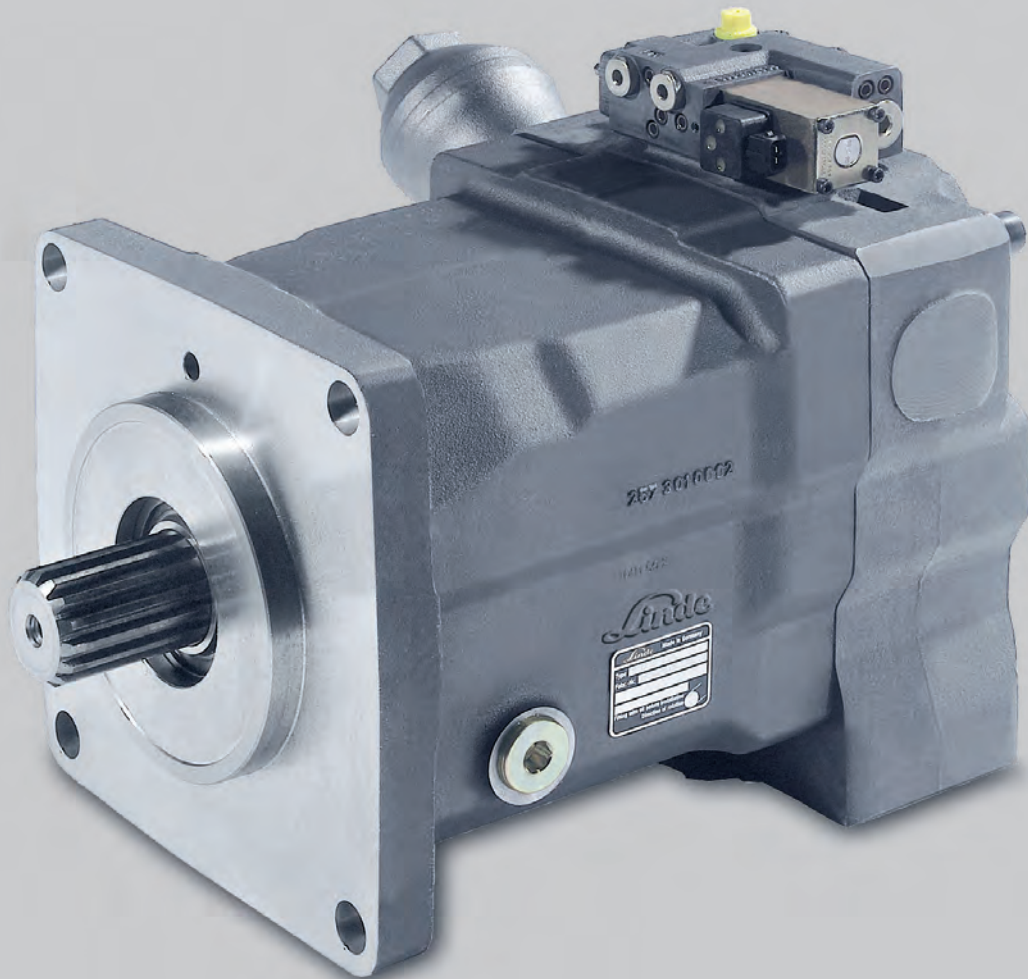

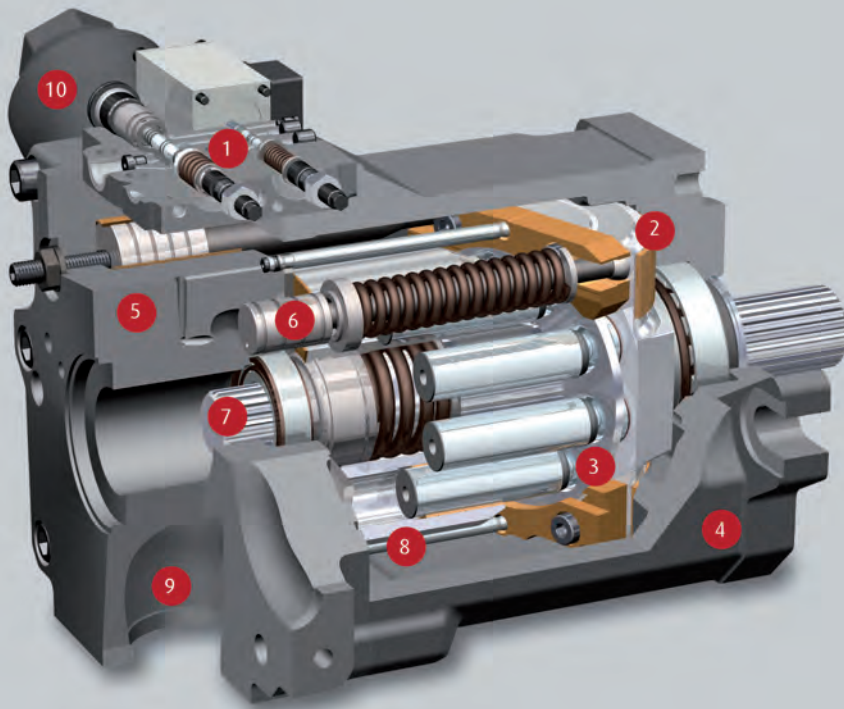

- 1 **LS-controller**
optimum utilisation of power
- 2 **swash plate**
hydrostatic bearing
- 3 **piston-slipper assembly**
21° swash angle
- 4 **housing**
one-piece design for high rigidity
- 5 **valve plate housing**
highly integrated
- 6 **two control pistons**
servo-controlled swash plate
- 7 **power take-off**
for mounting of additional pumps
- 8 **cylinder barrel**
compact due to 21° technology
- 9 **suction channel**
optimized suction capacity
without tank pressurization
- 10 **SPU**
reduced pressure pulsation
over the entire operating range

Design characteristics

- >> high pressure axial piston pump in swash plate design for open loop systems
- >> clockwise or counter clockwise rotation
- >> self-priming at high nominal speed
- >> higher rotating speed by tank pressurization or swash angle reduction
- >> adaptive noise optimization SPU
- >> decompression fluid is drained via pump housing for suction side stability
- >> exact and rugged load sensing controls
- >> SAE high pressure ports
- >> SAE mounting flange with ANSI or SAE spline shaft
- >> through shaft SAE A, B, B-B, C, D and E
- >> optional tandem and multiple pumps

Product advantages

- >> energy saving operation by "flow on demand" control
- >> dynamic response
- >> excellent suction up to rated speed
- >> noise optimization over the entire range of operation
- >> optimal interaction with Linde LSC-directional control valves and LinTronic
- >> compact design
- >> high power density
- >> high pressure rating
- >> high reliability
- >> long working life

Linde Hydraulics product range

Find the right products for your application.

Product range

Product		Application	Linde product name
Pump	Self-regulating pump	open loop operation	HPR-02
	Variable pump	closed loop operation	HPV-02
Motor	Variable motor	closed and open loop operation	HMV-02, CMV
	Regulating motor	closed and open loop operation	HMR-02
	Fixed motor	closed and open loop operation	HMF-02, CMF
		open loop operation	HMF-02 P
Valve technology	LSC manifold plate	closed and open loop operation	HMA-02
		open loop operation	VT modular
	Monoblock	open loop operation	Monoblock
Electronics	Electronic control unit	closed and open loop operation	iCon
	Software	diagnosis and configuration	LinDiag®

Content HPR-02.

General technical data	4	>> E1L. LS with electric override	24
Operational parameters		>> H1L. LS with hydraulic override	25
>> Life time recommendations	6	>> Electrical properties	26
>> Tank connection, filtration, mounting orientation	7	>> Pump controllers with position feedback	27
>> Pressure fluids	8	>> TL2. LS with hyperbolic power limitation	29
Linde LSC-System	9	>> LEP. LS with electro-proportional flow	
Noise reduction. SPU silencer	10	limitation and pressure cut-off	30
Torque transmission	12	>> ETP. Electro-proportional flow setting,	
>> Mounting flange	13	hyperbolic power limitation and pressure cut-off	31
>> Drive shaft	14	Dimensions	
>> Pumps according to ISO 3019-2 and SAE J617a	15	>> Controllers	32
>> PTO through drive	16	>> Single pumps for LP, E1L, H1L	38
>> PTO flange and output shaft	17	>> Single pumps for TL2, LEP, ETP	40
Gear pumps	18	>> Double pumps and plug-in pumps	42
Controllers	20	>> Multiple pumps	44
>> LS. Load Sensing	21	Modular system features	46
>> LP. LS with hydraulic pressure cut-off	22	Print media overview	47
>> E1L/H1L. LS with electric/hydraulic override	23	Contact	48

The data on which this brochure is based correspond to the current state of development. We reserve the right to make changes in case of technical progress. The dimensions and technical data of the individual installation drawings are prevailing. The features listed in this data sheet are not available in all combinations and nominal sizes. Our sales engineers will be happy to provide advice regarding the configuration of your hydraulic system and on product selection.

General technical data.

Overview of technical data

Rated size			55	75	105	135	165	210	280	105D	125D	165D	
	Max. displacement	cc/rev	55	75.9	105	135.7	165.6	210.1	281.9	210	250	331.2	
Speed	Max. operating speed Without tank pressurization*	rpm	2700	2500	2350	2300	2200	2100	2000	2450	2400	2100	
Volume flow**	Max. oil flow	l/min	148.5	189.8	246.8	312.1	364.3	441.2	563.8	514.5	600.0	695.5	
Pressure	Nominal pressure	bar	420	420	420	420	420	420	420	420	380	420	
	Max. pressure***	bar	500	500	500	500	500	500	500	500	420	500	
	Perm. housing pressure	bar	2.5										
Torque**	Max. input torque Max. oper. pressure and Vmax	Nm	368	507	702	907	1107	1404	1884	1245	1245	1964	
Power**	Corner power (theoretical) at nominal pressure & max. operating speed	kW	104.0	132.8	172.7	218.5	255.0	308.8	394.7	319.4	337	431.8	
Response times Measured at fluid viscosity 20 cSt and input speed 1500 rpm	V _{max} -> V _{min} Swashing at constant max. system pressure HP	HP 100 bar	ms	120	120	120	140	150	200	300	200	140	150
		HP 200 bar	ms	70	70	70	70	130	170	270	170	120	130
	V _{min} -> V _{max} Swashing from stand-by pressure and zero flow to system pressure HP	HP 100 bar	ms	180	180	180	180	180	180	430	160	180	180
		HP 200 bar	ms	160	160	160	160	160	160	350	160	160	160
Permissible shaft loads	Axial	N	2000										
	Radial	N	on request										
Permissible housing temp.	Perm. housing temp. With min. perm. viscosity > 10 cSt	°C	90										
Weights	HPR-02 without Oil (approx.)	kg	39	39	50	65	89	116	165	96	113	177	
	Max. moment of inertia	kgm ² x 10 ⁻²	0.79	0.79	1.44	2.15	3.41	4.68	8.34	2.88	2.95	6.88	

*) Higher rotating speed by tank pressurization or swash angle reduction. See <<Suction speed>>

**) Theoretical data of a single unit without efficiency effects

***) Highest transient pressure, that can temporarily occur

Standard Linde-name plate

Each Linde Hydraulics unit features a name plate showing the type and the serial number. For a single order via 'open variant' a customer-specific number or free text with up to 15 characters can be stamped on the name plate.

Type	HPR 105-02 R 2683	Series 02 self-regulating pump, rated size 105 Right hand rotation The last 4 figures of the Bill of Material
Serial-No.	H2X 254 T 12345	Type number of HPR 105-02 Letter indicating year of production Serial Number
Part No.	12345678	Free text field for up to 15 characters



General technical data.

Selection diagram

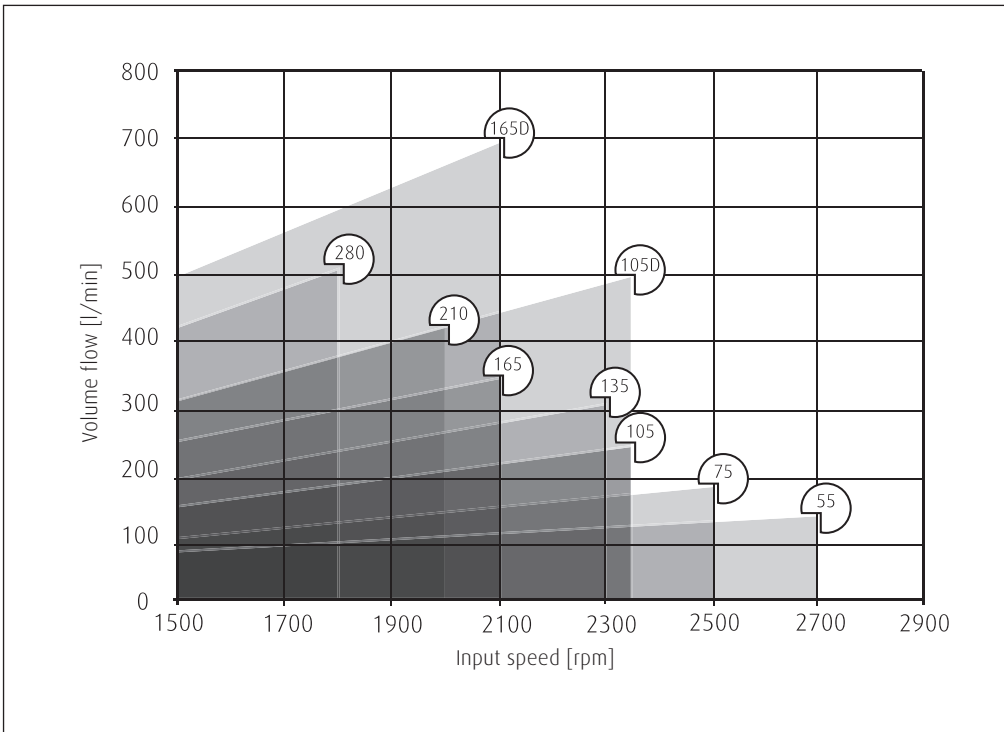

Suction speeds

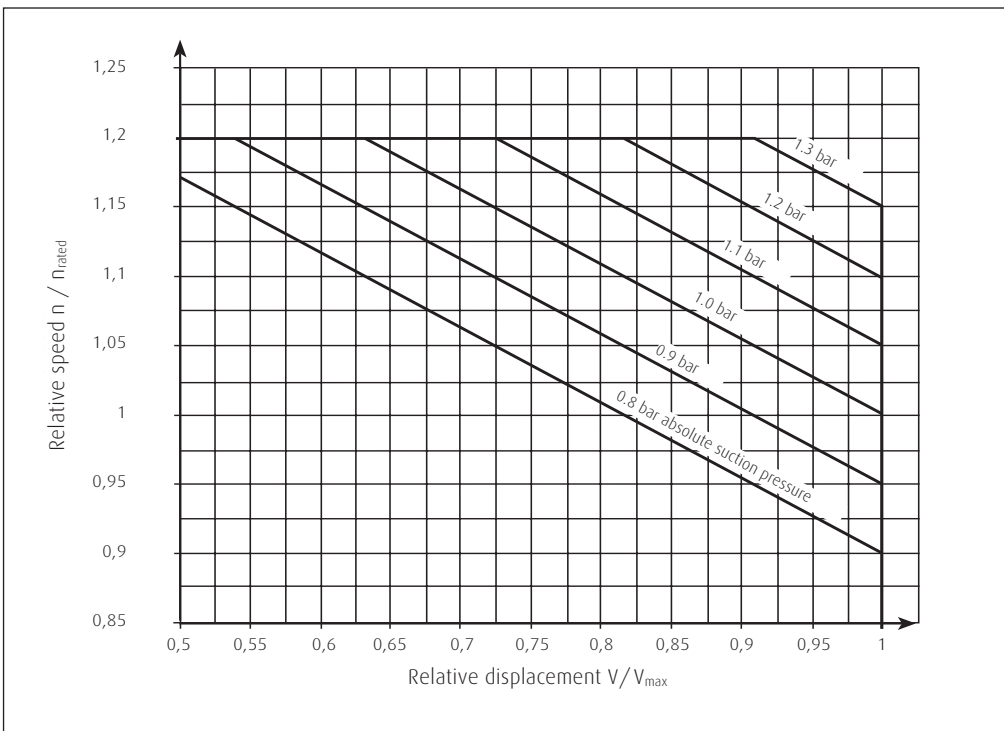

Operational parameters. Tank connection, filtration, mounting orientation

Tank connection

The leakage and decompression oil generated during pump operation is drained from the rotating group into the pump housing. Excessive housing pressure must be avoided through suitably dimensioned piping between the housing and the tank.

Filtration

High purity oil can extend the service time of the hydraulic system significantly. In order to guarantee long-term proper function and high efficiency of the hydraulic pumps the purity of the pressure fluid must comply with the following criteria.

>> For reliable proper function and long service life	18/16/13 in accordance with ISO 4406 or better		
>> Minimum requirements	20/18/15 in accordance with ISO 4406		
>> Commissioning	The minimum purity requirement for the hydraulic oil is based on the most sensitive system component. For commissioning we recommend a filtration in order to achieve the required purity.		
>> Filling and operation of hydraulic systems	The required purity of the hydraulic oil must be ensured during filling or topping up. When drums, canisters or large-capacity tanks are used the oil generally has to be filtered. We recommend the implementation of suitable measures (e.g. filters) to ensure that the required minimum purity of the oil is also achieved during operation.		
>> International standard	code number according to ISO 4406		purity class according to SAE AS 4059
	18/16/13	corresponds to	8A/7B/7C
	20/18/15		9A/8B/8C

Mounting orientation

The preferred mounting orientation is generally horizontal. Pump configurations for vertical mounting with the shaft pointing upwards have an additional drain port "R" at the mounting flange. These units are available with certain combinations of features and have to be requested separately.

For further information concerning the installation of the unit please refer to the operating instructions manual.

Operational parameters. Pressure fluids

In order to ensure the functional performance and high efficiency of the hydraulic pumps the viscosity and purity of the operating fluid should meet the different operational requirements. Linde recommends using only hydraulic fluids which are confirmed by the manufacturer as suitable for use in high pressure hydraulic installations or approved by the original equipment manufacturer.

Permitted pressure fluids

- >> Mineral oil HLP to DIN 51524-2
- >> Biodegradable fluids in accordance with ISO 15380 on request
- >> Other pressure fluids on request

Linde offers an oil testing service in accordance with VDMA 24 570 and the test apparatus required for in-house testing. Prices available on request.

Recommended viscosity ranges

Pressure fluid temperature range	[°C]	-20 to +90
Working viscosity range	[mm ² /s] = [cSt]	10 to 80
Optimum working viscosity	[mm ² /s] = [cSt]	15 to 30
Max. viscosity (short time start up)	[mm ² /s] = [cSt]	1000

In order to be able to select the right hydraulic fluid it is necessary to know the working temperature in the hydraulic circuit. The hydraulic fluid should be selected such that its optimum viscosity is within the working temperature range (see tables).

The temperature should not exceed 90 °C in any part of the system. Due to pressure and speed influences the leakage fluid temperature is always higher than the circuit temperature. Please contact Linde if the stated conditions cannot be met or in special circumstances.

Viscosity recommendations

Working temperature [°C]	Viscosity [mm ² /s] = [cSt] at 40 °C
approx. 30 to 40	22
approx. 40 to 60	32
approx. 60 to 80	46 or 68

Linde LSC-System.

The Linde Synchron Control System (LSC-System) for open loop hydraulic circuits enables demand-orientated pump volume control based on load sensing technology (LS technology). A LSC-System compensates the effect of varying loads, varying numbers of actuators and different load levels at different actuators. This happens automatically, thereby making machine operation more convenient since, unlike in other systems, continuous corrective action is no longer required. The LSC-System enables high-efficiency hydraulic systems to be realized that are strictly orientated to the machine functions. Our application specialists will be happy to provide advice for individual machine configurations.

Functionality

- >> Demand-oriented pump control
- >> Excellent precision control characteristics without readjustment
- >> Exact reproducibility of machine movements through exact control of actuators
- >> Dynamic response characteristics
- >> Load-independent, synchronous movements of several actuators
- >> "Social" oil distribution even in the event of overload
- >> Automatic venting of directional control valve end caps
- >> Optimum movement continuity even for combined movements

Further optional functions such as

- >> Priority control of individual actuators
- >> Output control
- >> High-pressure protection
- >> Regeneration function
- >> Combined function shuttle valve
- >> Load holding function

Machine equipment

- >> Customized system design for optimum implementation of customer requirements
- >> Optimum utilization of the installed power with simultaneous improvement of energy consumption
- >> High flexibility through manifold plates
- >> Compact, integrated solutions
- >> Modular design of valve sections
- >> Add-on cylinder valves for direct and fast cylinder supply, no additional hose burst protection required
- >> Optimized piping

Benefits

- >> Perfect matching of the individual operating functions for customized machine characteristics
- >> Efficient and dynamic machine control for short operating cycles
- >> Optimized energy balance for reduced fuel consumption and enhanced handling performance
- >> Simple and safe machine operation for non-fatigue and efficient working
- >> Unsurpassed reliability even under harsh operating conditions
- >> Reduced installation times

Noise reduction. SPU silencer

In hydraulic systems pressure pulsations can lead to noise emission. These pressure pulsations are a result of the inherent non-uniformity of the volume flow in rotary piston pumps. In open loop hydraulic circuits pressure pulsations primarily originate from within the hydraulic pump during the compression stroke, i.e. when a piston coming from the low-pressure side (suction side) enters the high-pressure side, where it is suddenly subjected to high pressure. The higher the pump speed and the pressure difference between the low-pressure and high-pressure side, the more pulsation energy is added to the hydraulic system via the hydraulic fluid. Pressure pulsations can cause components of the hydraulic system or the machine to oscillate, thereby generating noise that is perceivable for the human ear.

In principle noise emissions from machinery with hydraulic systems can be reduced in the following ways:

- >> Reduction of operating pressure and speed. This reduces the pulsation energy introduced into the hydraulic system
- >> Primary measures for optimizing the compression stroke in rotary piston machines with the aim of reducing pulsation
- >> Secondary measures such as vibration-optimized design and installation of machine components and sound-proofing for noise suppression

Noise Generation

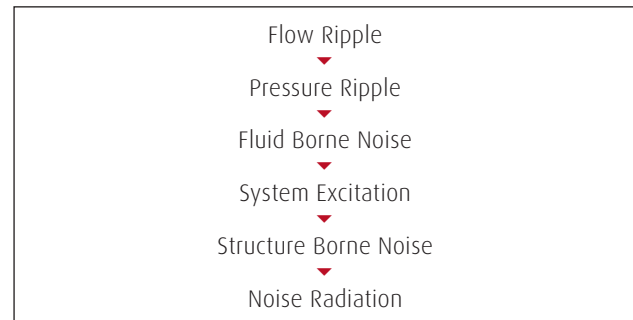

Noise reduction. SPU silencer

All Linde hydraulic pumps are optimized with respect to pulsation characteristics and therefore noise generation. In addition to common primary measures such as exclusive use of pulsation-optimized port plates, Linde Hydraulics offers the SPU silencer for HPR-02 open loop pumps. Without affecting the functionality and efficiency of the pump, this system reduces pressure pulsations by up to 70 %, irrespective of pressure, speed or temperature. The SPU system is adaptive over the entire operating range. No setting up or maintenance is required.

Pressure pulsations with and without SPU

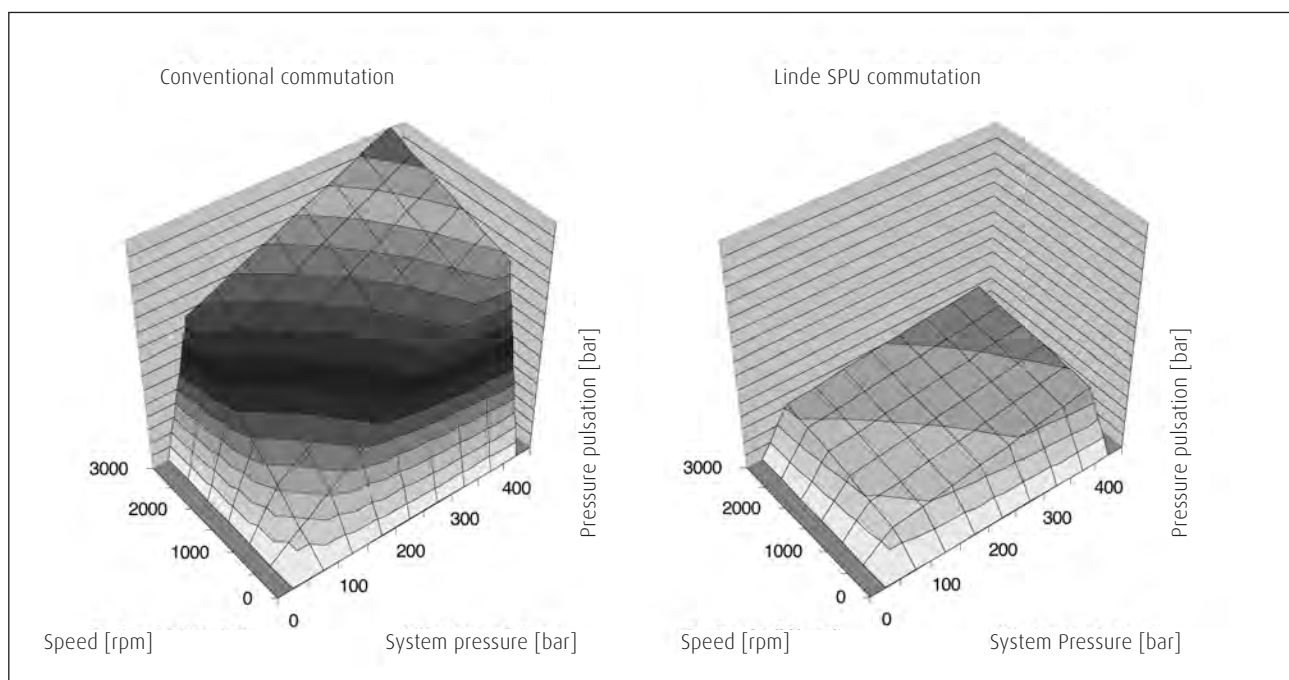

Noise reduction. SPU silencer

SPU silencer function

- >> Reduction of pressure pulsations over the entire operating range
- >> Reduction of noise emission by approx. 50 % (equals approx. 3 dB(A))
- >> Reduction of volume flow fluctuations
- >> No impairment of efficiency
- >> Ready for use immediately, no maintenance required
- >> Simple and rugged design
- >> Minimum increase in weight and volume

HPR-02 with SPU



The following diagrams illustrate the immediate effect of pulsation level reduction via SPU on the sound pressure level and therefore the perceived noise emission.

Comparison of sound pressure levels for a HPR 75-02 pump with and without SPU

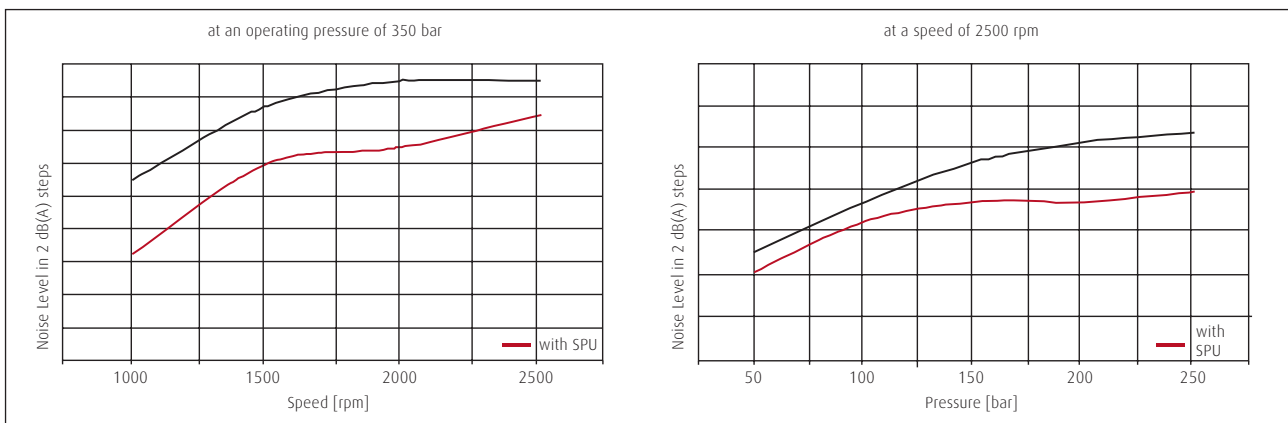

Comparison of resulting noise emission

Shown in 2 dB(A) steps over a typical diesel engine operating speed range.

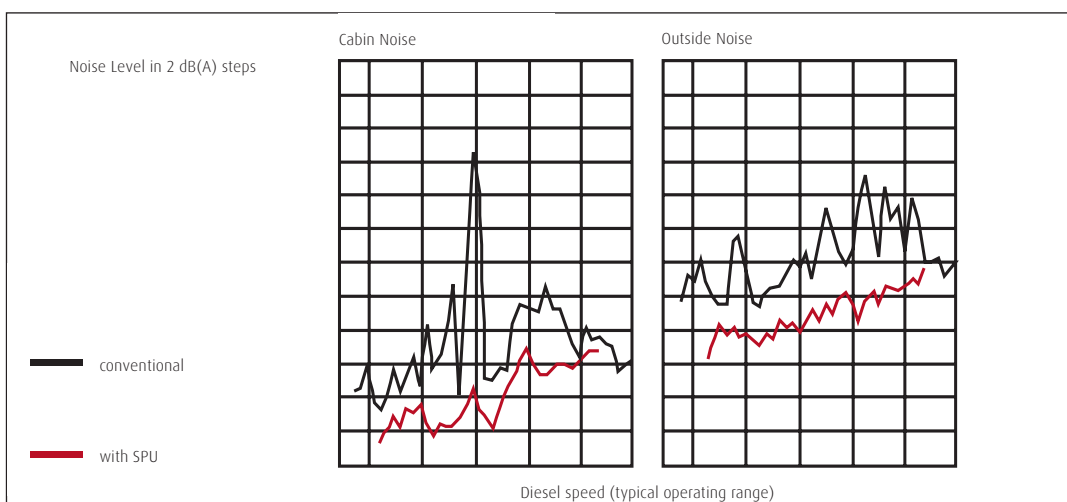

Torque transmission.

Depending on the selected components, different torques may be transferred. Please ensure that the load transfer components such as mounting flange, PTO-through shaft and additional pumps are designed adequately. Our sales engineers will be pleased to provide design advice.

Torque transmission of HPR-02

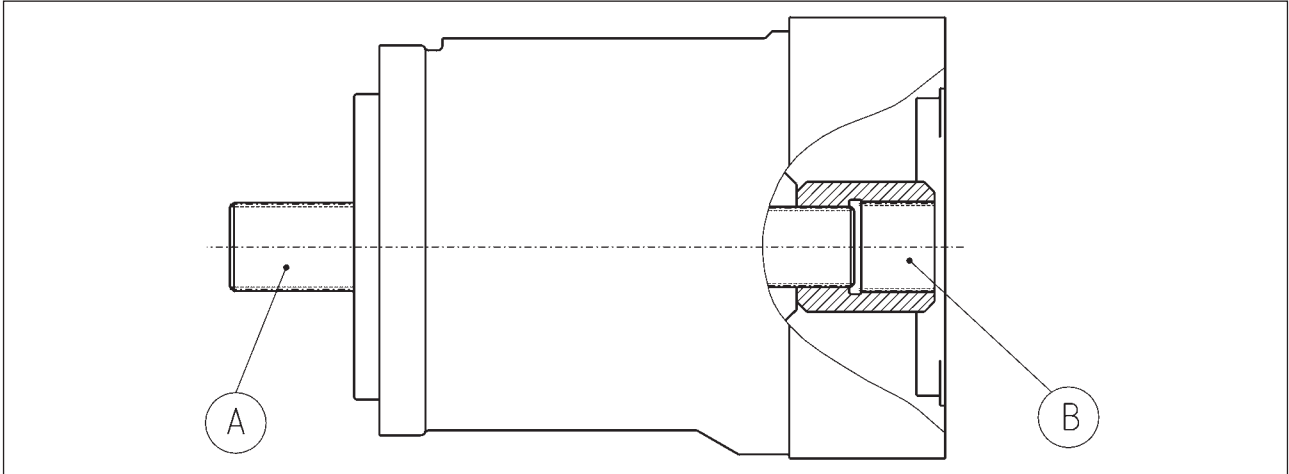

This shows the input side (A) and PTO- / output side (B) of a HPR-02 pump.

The information on the following pages refers to

- >> mounting flange and drive shaft (A)
- >> PTO flange and through shaft (B)

A) Flange profile

Bolt hole dimensions		Rated size HPR-02								
		55	75	105	135	165	210	105 D	280	165 D
M1 inside diameter	mm	17.5	17.5	17.5	21.5	21.5	22	17.5	22	17.5
M2 outside diameter	mm	34	34	40	40	40	-	40	-	-
M3 bolt hole length	mm	20	20	20	20	25	26	20	30	25

Bolt hole diameter

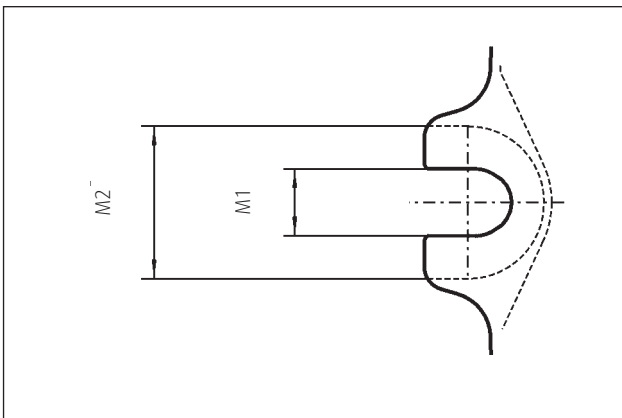

Bolt hole length

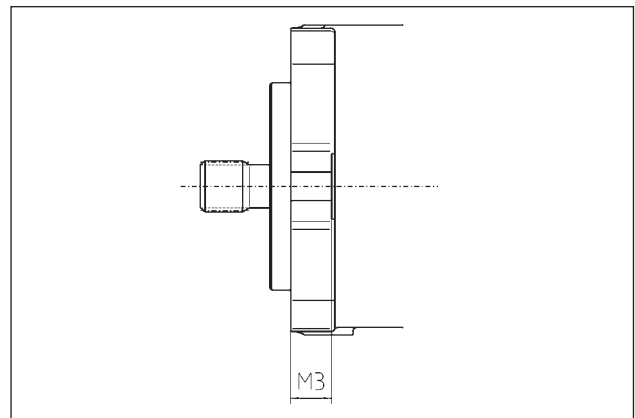

Torque transmission. Mounting flange

Mounting flange in accordance with SAE J744	For rated size	Mounting				Dimensions				
		Washer	Screw	Torque (8.8) [Nm]	Torque (10.9)* [Nm]	K [mm]	D [mm]	H [mm]	V [mm]	G [mm]
SAE C, 2 hole	55, 75, 105	17x33x10	M16	195	275	181.0	127	-	-	-
SAE C, 2 hole with 4 additional threads M12	105	17x33x10	M16	195	275	181.0	127	-	-	114
SAE C, 2 hole with 4 additional holes (d=10.5 mm)	105D	17x33x10	M16	195	275	181.0	127	178	178	-
SAE D, 2 hole	135	21x37x8	M20	385	540	228.6	152.4	-	-	-
SAE D, 2 hole with 4 additional threads M16	135	21x37x8	M20	385	540	228.6	152.4	-	-	138
SAE D 2 hole with additional bolt holes (d=17.5 mm)	165 & 165D	21x37x8	M20	385	540	228.6	152.4	230	190	-
SAE E, 4 hole	210 & 280	-	M20	385	540	224.5	165.1	-	-	-

*) Option for standard design, necessary for tandem units

2-hole flange

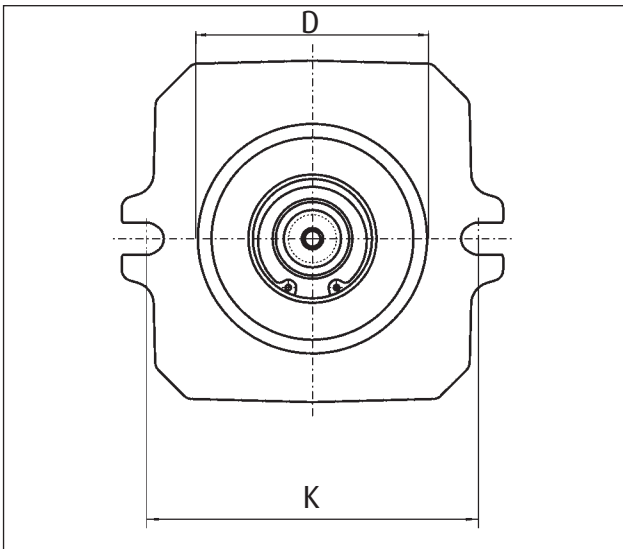

4-hole flange

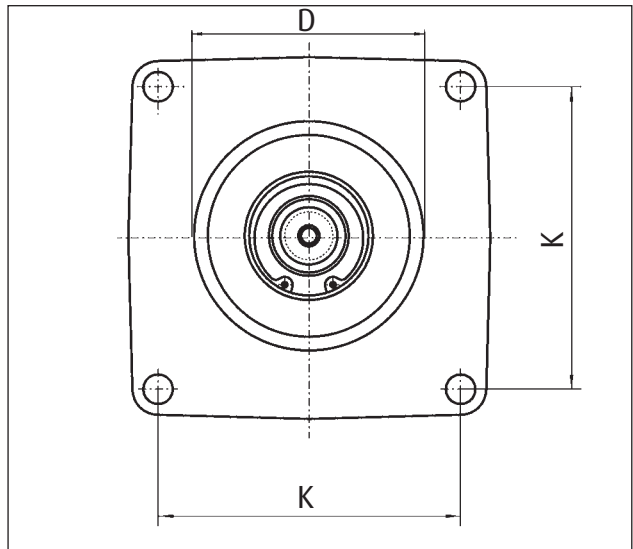

2-hole flange with 4 additional threaded holes

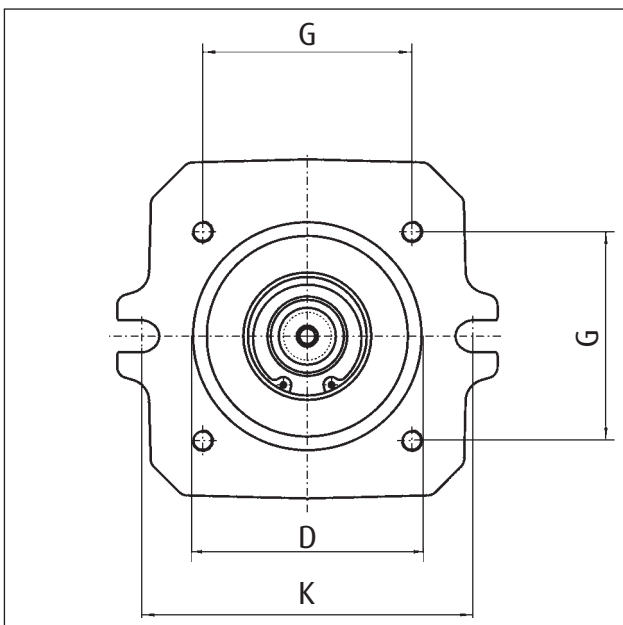

2-hole flange with 4 additional bolt holes

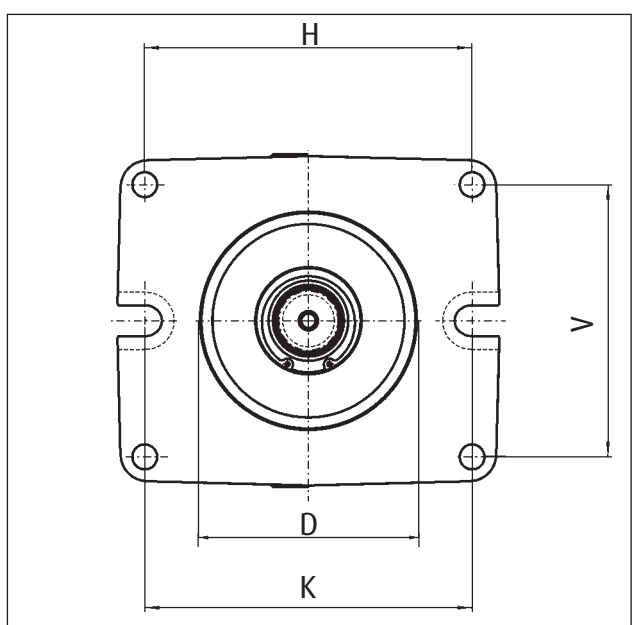

Torque transmission. Drive shaft

A) Dimensions drive shafts

Shaft spline (in accordance with ANSI B92.1)	SAE-J744 Code (for centring and shaft)	Outside diameter W1 [mm]	Useable spline length W2 [mm]	Shaft type	Available for rated size								
					55	75	105	105D	135	165	165D	210	280
12/24, 14 t	C	31.22	30	2	x	x	x	-	-	-	-	-	-
16/32, 21 t		34.51	39.5	1	-	x*	-	-	-	-	-	-	-
12/24, 17 t	C-C	37.68	30	2	-	-	x	x	x	-	-	-	-
16/32, 23 t		37.68	38.5	1	-	-	x*	x	-	-	-	-	-
8/16, 13 t	D, E	43.71	50	2	-	-	-	-	x	x	x	-	-
16/32, 27 t		44.05	62	1	-	-	-	-	x	x*	x	x	-
8/16, 15 t	F	50.06	58	1	-	-	-	-	-	-	-	x*	x

*) Recommended for tandem configurations

A) Linde Hydraulics shaft types

Type 1. Without undercut

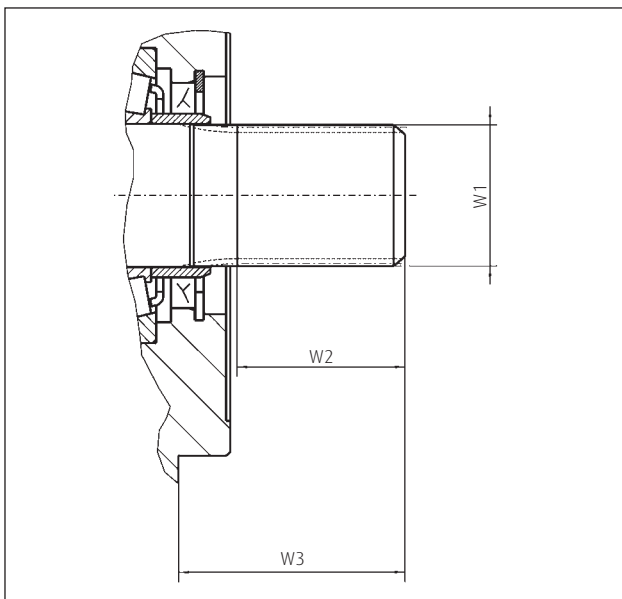

Type 2. With undercut

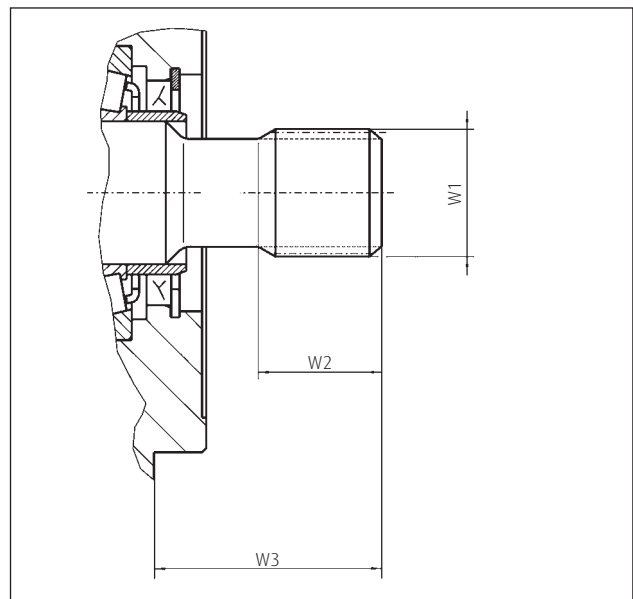

Rated size		55	75	105	105D	135	165	165D	210	280
Excess length W3	mm	54	55	55	61.3	75	75	75	75	75

Torque transmission. Pumps according to ISO 3019-2 and SAE J617a

The previously given information and dimensions refer to pumps according to ISO 3019-1 (SAE J 744). In addition to that, certain configurations are available according to ISO 3019-2. These units offer an additional drain port "R" at the mounting flange for upright installation and a keyed drive shaft.

Rated size		105	280
Mounting flange		125A2SW	224B4SW
Mounting		2-hole	4-hole
Screw hole diameter	M1	17.5	22
Screw contact surface	M2	40	40
Clamping length	M3	30	30
Centring	D	125	224
Mounting hole distance	K	180	198
Shaft diameter	W1	40	60
Key acc. to DIN 6885	W2	12x8x80	18x11x100
Excess length	W3	92	115
Height	W4	23	53
Port R	Size	M14x1.5 13 deep	
	Position	bottom, as port "T"	side, as port "U"
	R(L)	15.5	15
	R(H)	approx. 80	50
	R(B)	40	152

>> Further dimensions and position of the other ports, see <<Dimensions. Single pumps HPR-02 for TL2, LEP, ETP>>

Detailed shaft view

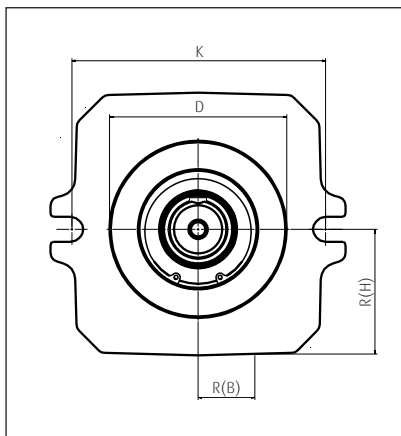

View on R

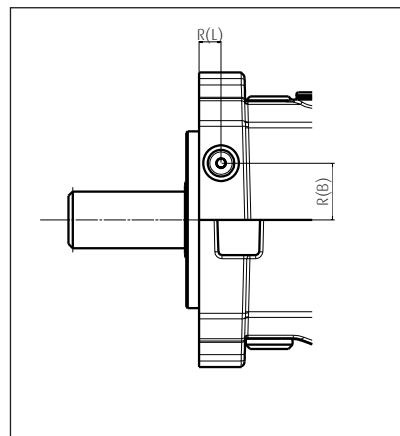

Mounting flange

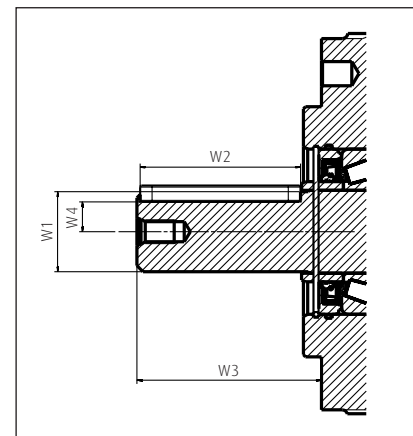

Linde HPR pumps can be delivered matching a flange according to SAE J617a. The pumps are therefore equipped with an adaptor. Depending on the rated size, the base unit is a standard HPR-02 or a plug-in type HPR-02. The plug-in-flange is shown in section <<Dimensions. Double pumps and plug-in pumps>>.

According to SAE J617a	Rated size	Base unit
SAE 3	105, 105D, 135	plug-in
SAE 3	165, 165D	SAE D 2-hole with 4 additional bolt holes
SAE 4	105, 105D, 135	plug-in
SAE 5	55, 75, 105	SAE C 2-hole

Torque transmission. PTO through drive

Linde pumps can be combined into tandem and multiple pumps. The combination options are determined by the permitted transfer torque. The following data refers to the PTO (pump output side, without further attachments).

B) Dimensions PTO

Rated size		55	75	105	135	165	210	280
Z drive hub profile (in accordance with ANSI B92.1)		16/32, 18 t	16/32, 18 t	16/32, 19 t	16/32, 21 t	16/32, 23 t	16/32, 24 t	16/32, 27 t
D1	mm	47	47	48	54	55	63	72
D2 spigot pilot diameter	mm	82.55						
D3	mm	89.5						
D4		M 10						
D5 max. bearing clearance	mm	30	35	38	43	42	46	51
L1	mm	1.5				1.9	1.9	1.9
L2 adapter length	mm	7				8	8	8
L3	mm	9						
L4 minimum distance	mm	35	39	33	35	57.8	46	47.5
L5 usable spline length	mm	18	18	24	15.8	24.4	29.5	39
L6 distance to bearing	mm	48	48	52.7	54.2	83.3	46	86
L7 min. bearing clearance	mm	3				5		0.7
L8 hole distance 2-hole	mm	106.4						

B) Dimensions PTO

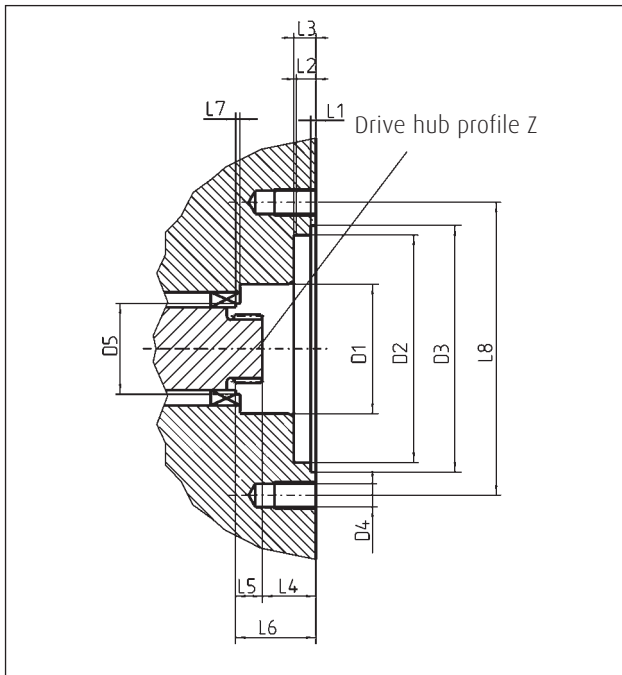

Torque transmission. PTO flange and output shaft

Beside the combination of the HPR with other HPRs or HPVs to create multiple and tandem units (see section <<Dimensions. Multiple pumps>>), single HPRs can be prepared ex works for the combination with other pumps. Depending on the rated size, we offer different centring for the rear pump. A matching coupling muff for the drive shaft can also be selected. Currently, the following combinations are available. For more information about the output torque, see annotations to table at chapter <<General technical data>>.

B) PTO mounting possibilities

Centring symbol acc. to SAE J 744	Coupling muff, acc. to ANSI B92.1	Rated size						
		55	75	105	135	165	210	280
Directly mounted Linde gear pumps		X	X	X	X	X	X	X
A	without	X	X	X	X	X	X	X
A	16/32 9 t (A)	X	X	X	X	X	X	-
A	16/32 11 t	-	-	-	-	-	X	-
A	16/32 13 t	-	-	X	X	-	X	X
B	without	X	X	X	X	X	X	X
B	16/32 13 t (B)	X	X	X	X	X	X	X
B	16/32 15 t (B-B)	X	X	X	X	-	-	X
C	without	X	X	X	X	X	X	X
C	12/24 14 t (C)	X	X	X	X	X	X	X
C	16/32 21 t	-	X	X	X	-	X	-
C	16/32 23 t	-	-	X	X	X	X	-
D	without	-	-	-	X	X	X	X
D	8/16 13 t (D)	-	-	-	X	-	-	-
D	12/24 17 t	-	-	-	X	-	-	-
D	16/32 27 t	-	-	-	X	X	X	-
E	without	-	-	-	-	-	X	X
E	16/32 27 t	-	-	-	-	-	X	-

B) Output shaft transfer torque

Rated size		55	75	105	135	165	210	280
Continuous transfer torque	Nm	219	302	418	540	659	836	1122
Max. transfer torque	Nm	433	598	763	1069	1069	1655	2221

Gear pumps.

The gear pumps are available in two designs. Internal gear pumps (IGP) and external gear pumps (EGP). Both types can be used for the control circuits as well as the cooling circuit. The suction is always external for both types, when used in combination with a HPR-02. The internal connection of the IGP is closed.

Internal gear pumps offer a cold start valve and a PTO interface for mounting further pumps. The possible combinations of IGP and EGPs are determined by PTO option and the permitted shaft torque.

Overview gear pumps

Displacement	cc/rev	16	19	22.5	31	38	44
Type of gear pump		IGP	EGP	IGP	EGP	EGP	EGP
Mounting flange and drive shaft profile		SAE A 16/32, 18 t	SAE A 16/32 9 t	SAE A 16/32, 18 t	SAE A 16/32, 9 t	SAE A 16/32, 13 t	SAE A 16/32, 13 t
Type of suction in conjunction with HPR-02		external					
Max. perm. operating pressure <small>Observe max permissible rated pressures for filter and cooler</small>	bar	40	210	40	165	275	220
Supply pressures min.	bar	0.8 (absolut)					
Supply pressures max.	bar	3.0 (absolut)					
Cold start relief valve		integrated	-	integrated	-	-	-

- >> Port names clockwise rotation: A pressure port, B suction port (as shown)
- >> Port names counter-clockwise rotation: A suction port, B pressure port (not shown)
- >> Ports according to ISO 6149-1
- >> Alternatively DIN 3852-1
- >> Suction port of the IGP according to ISO 8434-1 L28

External gear pump EGP

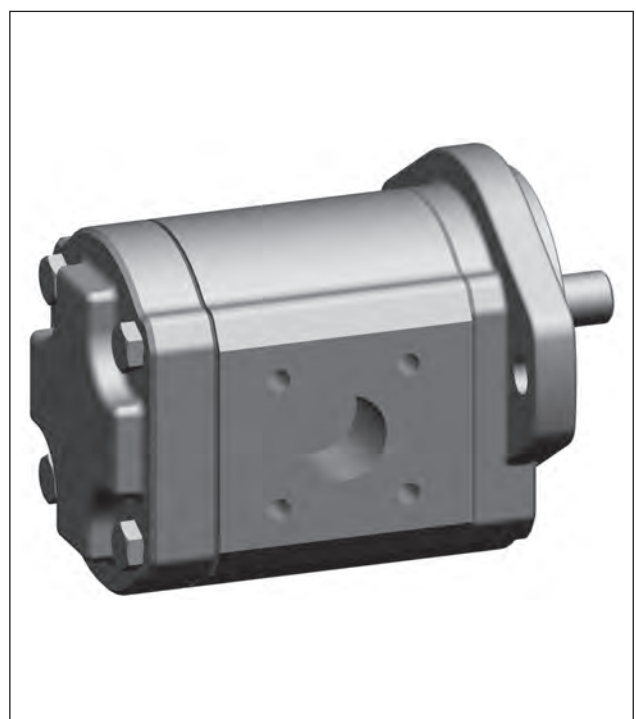
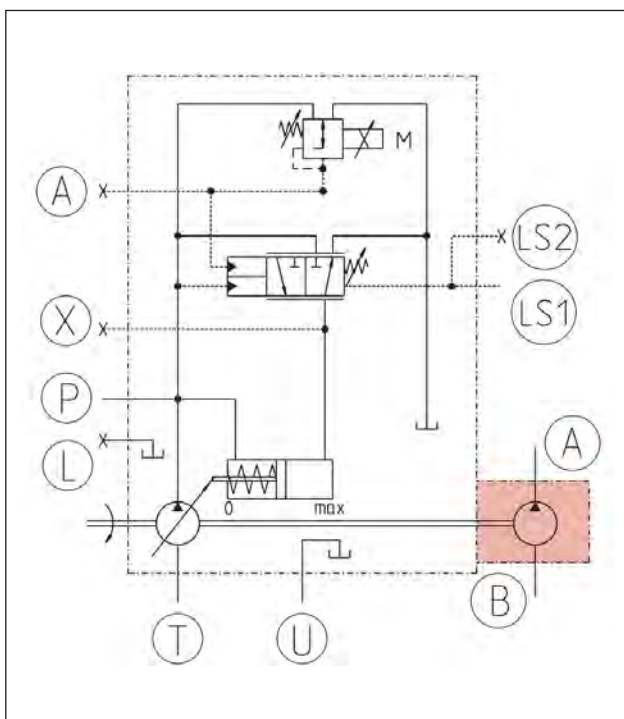

Gear pumps.

Internal gear pump IGP with external suction

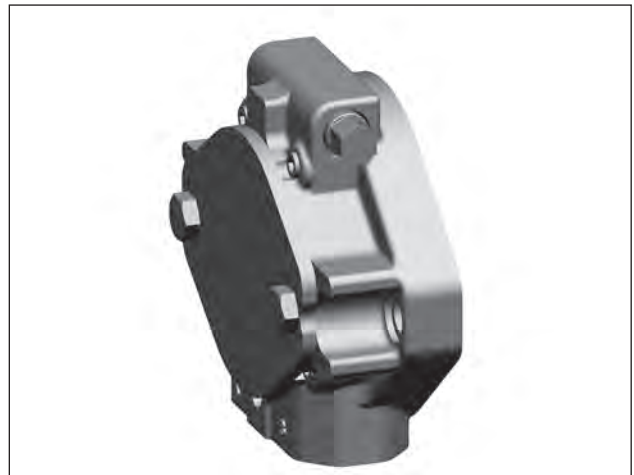
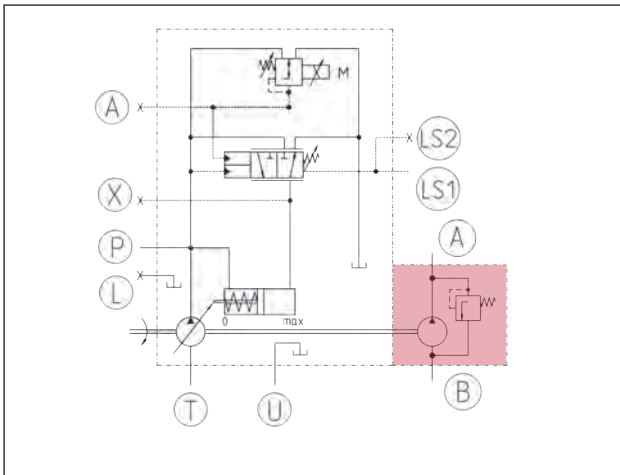

PTO flange with IGP

Flange profile 2-hole		SAE A	SAE B	SAE B-B	SAE C
Z internal spline profile in accordance with ANSI B92.1		16/32, 9 t	16/32, 13 t	16/32, 15 t	12/24, 14 t
D1 spigot pilot diameter	mm	82.55	101.6	127	
D2 thread size		M 10	M 12	M 16	
L1 hole distance	mm	106.4	146	181	
L2 adapter length	mm	7	11	13	
L3 flange length	mm	-	55	72	
Continuous transfer torque	Nm	75	175	250	
Maximum transfer torque	Nm	107	250		

PTO SAE A with IGP

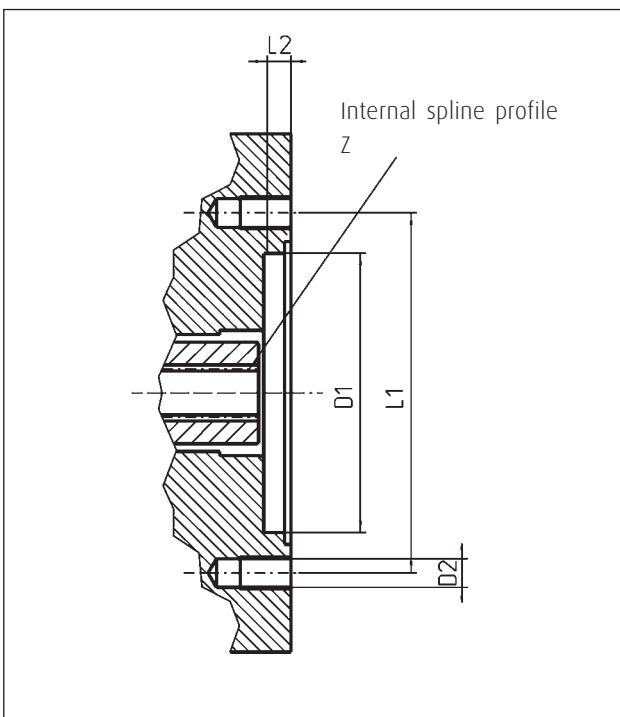

PTO SAE B, B-B, and C with IGP

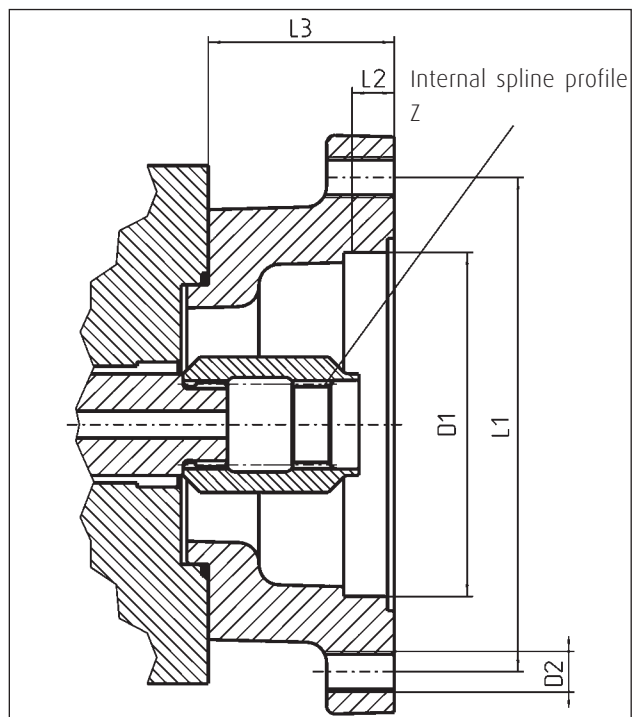

Controllers.

The modular controller unit enables a wide range of functional system requirements to be met. In all controller unit versions, the regulating functions are integrated in a housing in order to ensure direct signal transfer without delays and with maximum compactness. All controllers equipped with load sensing function are fully compatible with the Linde Synchron Control System (see section <<Linde LSC-System>>).

Technical data

Type of regulation	Additional function	Swashplate position feedback	Name
Load Sensing	With pressure cut-off	without	LP
	with Δp_{LS} override	without	E1L/H1L
	with hyperbolic power limiting	with	TL2
	electro-proportional flow limitation and pressure cut-off	with	LEP
Control	electro proportional flow setting, power limitation and pressure cut-off	with	ETP

Controllers without swashplate position feedback.

Mounting on the port plate housing



Controllers with swashplate position feedback.

Mounting on the pump housing

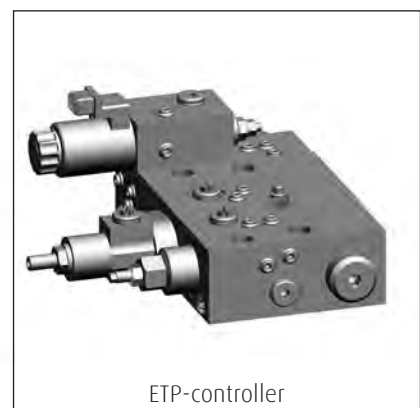
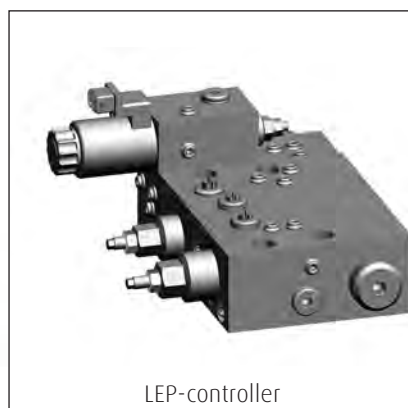

Controllers. LS. Load Sensing

Linde pumps with load sensing control enable the movement speed required of the selected actuator, e.g. of a boom, to be specified via the valve opening. The measured pump and load pressures are continuously balanced by the load sensing controller of the hydraulic pump.

Load Sensing. Flow on demand control

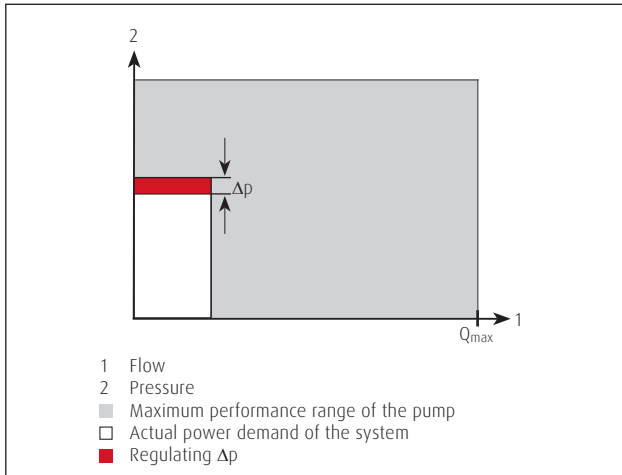

Self-regulating pump with LS-controller and measure orifice (in valve)

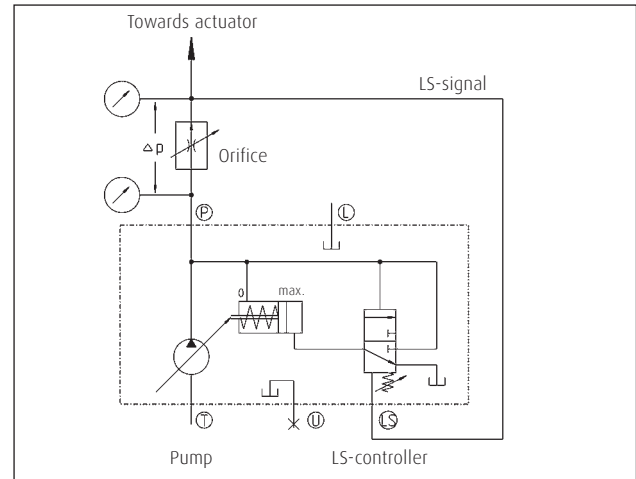

A pressure gradient is set at the controller, which is defined by the actuator requirements. The volume flow results from the orifice A of the control valve and the actual pressure gradient. Due to the LS-controller, the Δp corresponds to the setting value. If the required volume flow differs, the pump displacement is changed accordingly. This happens automatically and reduces the effort required by the operator. Since varying loads and varying numbers of actuators are compensated automatically. The Δp LS basic setting is possible from 16 to 27 bar with 20 bar as standard (the LS differential pressure influences the response times of the pump system).

LS-function at $\Delta p = \text{constant}$

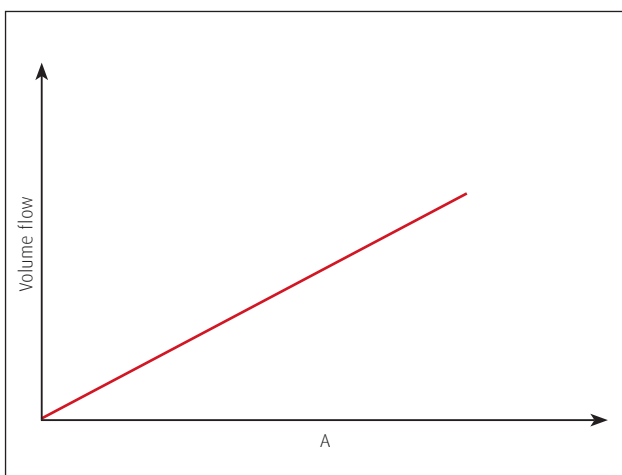

LS-function at area A = constant

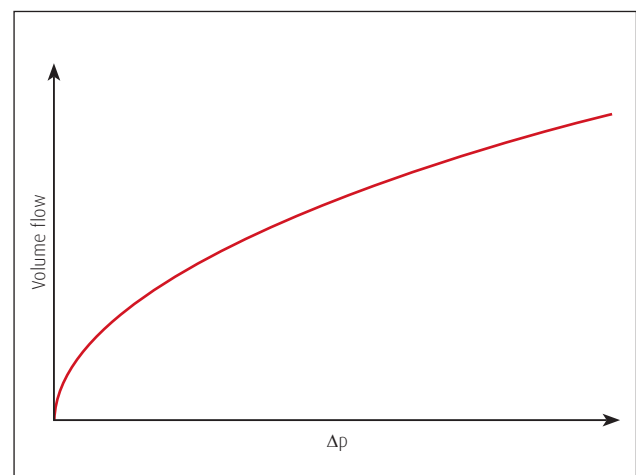

Benefits of LS-control

- >> Any volume flow below the pump's maximum can be set
- >> Response speed of the machine can be defined
- >> OEM-specific machine response is possible
- >> Optimum precision control capability

Demand-oriented pump control offers the following benefits

- >> Load-independent machine control
- >> Minimum heat generation
- >> Increased pump service life
- >> Low noise generation in the whole system
- >> Fewer components for the control mechanism
- >> Lower energy consumption, particularly with partial volume flow

Controllers. LP. Load Sensing with hydraulic pressure cut-off

In addition to the load sensing function the LP-controller offers maximum pressure limitation. Once the system pressure reaches the set pressure of the pressure cut-off valve, the LS-controller is overridden and the pump swashes back, whilst maintaining the system's regulating pressure. The hydraulic pump remains in this state until the system pressure falls below the set pressure. The hydraulic pump then returns to normal LS operation.

LP. LS with hydraulic pressure cut-off

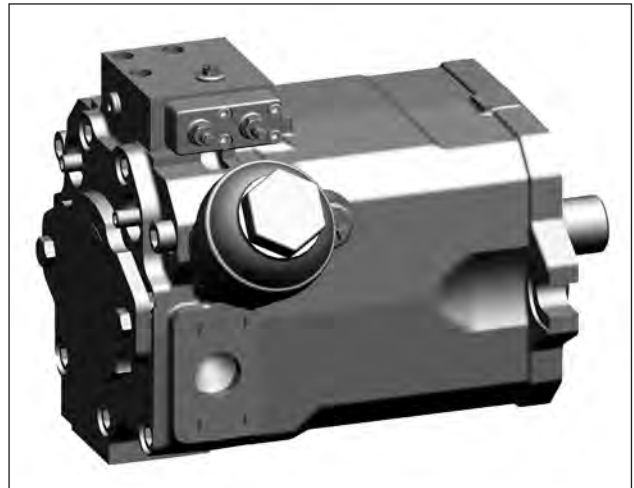
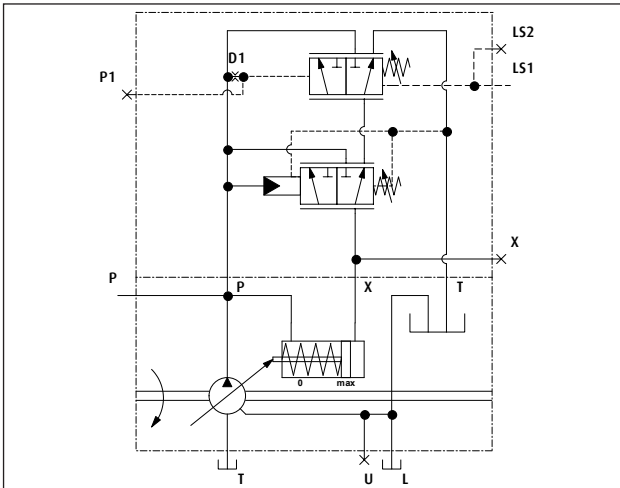

The maximum pressure cut-off valve prevents prolonged operation of pressure relief valves installed in the hydraulic system for protection. This has the following benefits for the hydraulic system:

- >> Operating pressure is maintained
- >> No operation in the overload range
- >> Any operating point under the power curve remains accessible
- >> Demand-oriented volume flow generation
- >> Minimum power loss
- >> Reduced heat and noise generation
- >> Longer service life of the pump and the entire hydraulic system
- >> Improved energy consumption of the overall system

LP-characteristic curve

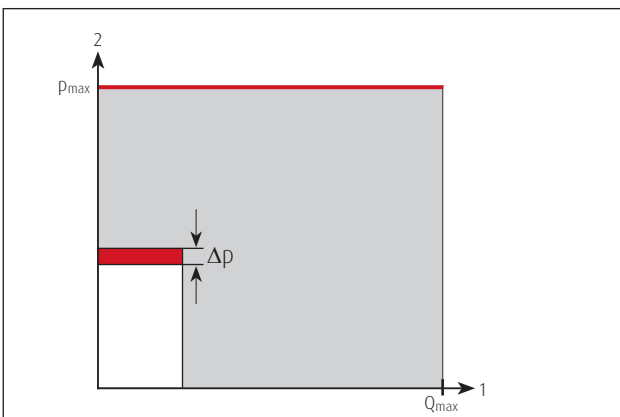

- 1 Flow
- 2 Pressure
- Maximum performance range of the pump
- Actual power demand of the system
- Regulating Δp
- Pressure cut-off characteristic

LP-controller



Possible maximum pressure control setting ranges

- >> 125 - 230 bar
- >> 231 - 350 bar
- >> 351 - 420 bar

Controllers. E1L/H1L. Load Sensing with electric / hydraulic override

In addition to the load sensing function, HPR-02 pumps with H1L or E1L controllers offer the possibility of overriding the Δp LS-signal hydraulically or electrically. This enables a so called mode control for selecting different operating points or enables a power limit regulation (underspeed control). The integration of all functions in the pump controller enables direct signal transfer without delay. The controller-specific data are independent of the nominal pump size.

Possible applications of the LS signal override

>> Mode-control

A mode control (mode selection) modulates electrically the Δp LS-signal at an orifice (e.g. directional control valve). The current Δp LS value is reduced proportionally or in steps and the pump output adjusted via the pressure reducing valve (see the diagrams on following pages.) In this way the volume flow of the pump can be reduced using the same orifice. In applications with proportional valves this leads to enhanced control resolution, enabling particularly precise and sensitive actuator movement.

>> Power limit regulation

Any reduction in the prime mover speed is detected in conjunction with an electronic control unit, and the pump's volume flow is limited through modulation of the Δp LS value to ensure that the maximum power capacity is not exceeded. The maximum prime mover power is thus available at all times, irrespective of ambient influences and the number of actuators.

In principle, the Δp LS value acting at the LS-pilot can be modulated down to zero, whereas modified response times of the pump system should be expected in the operating range near zero.

E1L/H1L-characteristic curve

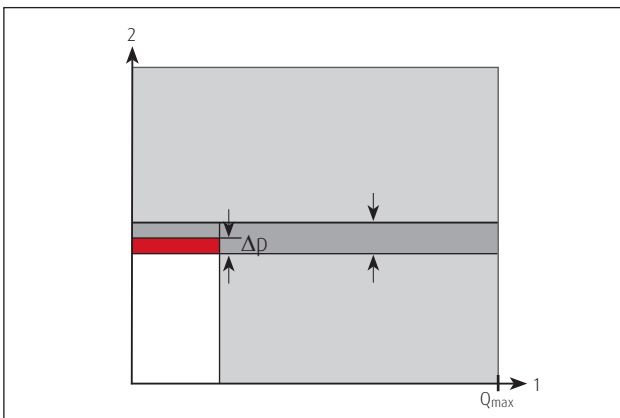

- 1 Flow
- 2 Pressure
- Maximum performance range of the pump
- Actual power demand of the system
- Mechanical Δp basic setting
- Effective, modulated regulating Δp

Pump volume flow at fixed orifice (e.g. directional control valve opening)

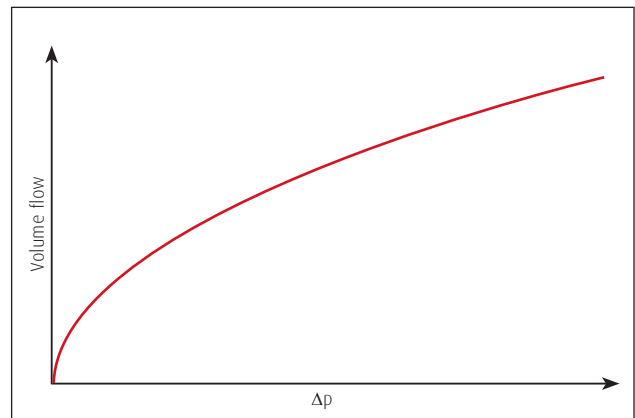

Controllers. E1L. Load Sensing with electric override

In addition to the load sensing function, the HPR-02 E1L offers an electric override for mode selection and power limit regulation (underspeed control). The integration of all functions in the pump controller enables direct signal transfer without delays. The controller-specific data are independent of the nominal pump size.

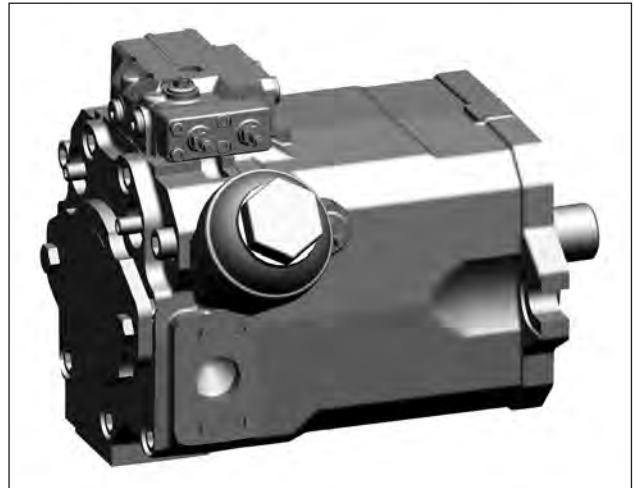
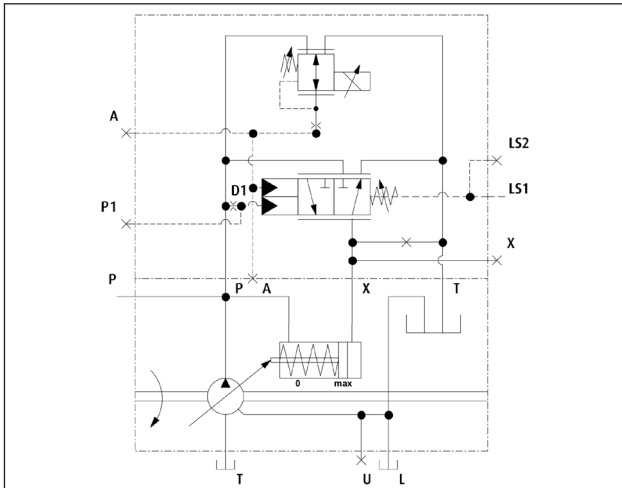

In the event of an electric override of the LS-signal, a pressure reducing valve is activated via the proportional solenoid. The control pressure generated in this way acts proportionally against the LS-spring, and the effect of the Δp LS signal is modulated accordingly. This causes the pump to swash back, thereby reducing its output. The function between control current (I) at the control solenoid and the associated Δp LS value is shown in the diagram. At the port "A", the control pressure can be picked up and forwarded to an H1L controller at another HPR pump, which follows the first pump with the E1L controller (master-slave-operation).

Δp LS-reduction

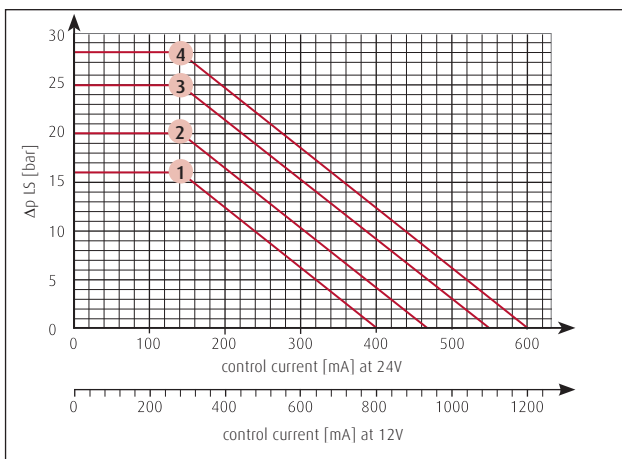

E1L-controller

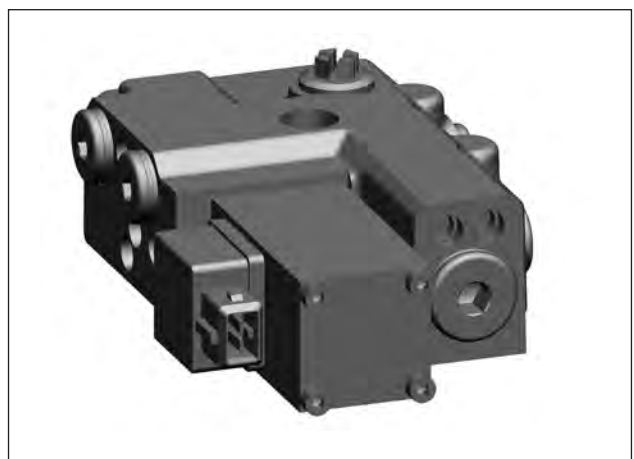

- 1 16 bar Δp setting
- 2 20 bar Δp setting
- 3 25 bar Δp setting
- 4 28 bar Δp setting

Controllers. H1L. Load Sensing with hydraulic override

In addition to the load sensing function, HPR-02 pumps with H1L-controller offer the possibility of overriding the Δp LS-signal hydraulically. This enables either a so called mode control for selecting different operation points or establish a power limit regulation (underspeed control). The integration of all functions in the pump controller enables direct signal transfer without delay. The controller-specific data are independent of the nominal pump size. The H1L-controller is particularly useful for tandem configurations of two HPR-02 pumps, in which the first is equipped with an E1L-controller. The second pump with H1L-controller uses the resulting hydraulic signal of the first controller and follows the first pump's actions (master-slave-configuration).

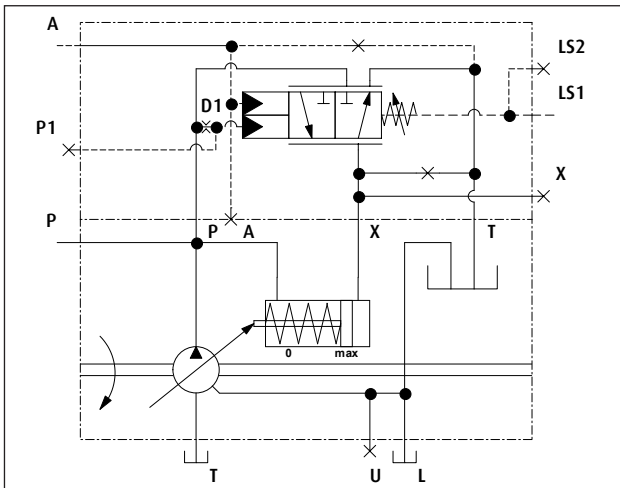

In the event of hydraulically overriding the LS-signal, a control pressure is applied to the port "A" of the controller. This pressure acts proportionally against the LS-spring, and the LS signal is modulated accordingly. This causes the pump to swash back, thereby reducing its output. The function between control pressure at the port A and the associated Δp LS value is shown in the following diagram.

Δp LS-reduction

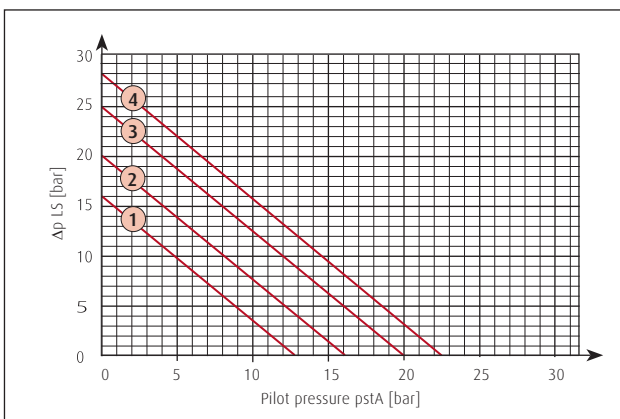

H1L-controller



- 1 16 bar Δp setting
- 2 20 bar Δp setting
- 3 25 bar Δp setting
- 4 28 bar Δp setting

Controllers. Electrical properties

Supply voltage = limiting voltage		V	12	24
Control types	Digital control via Pulse Width Modulation PWM		100 Hz rectangle, pulse duty ratio variable over control range	
	Analogue		Direct current with dither overlay (dither frequency nom. 35 Hz, duty cycle 1:1). Further details on request	
Connector type			DIN EN 175301-803, Deutsch, AMP Junior Timer (2-pin)	
Protection class			IP54 (DIN), IP67 (Deutsch), IP6K6K (AMP)	
Voltage type			Direct Current (DC)	
Power consumption		W	15.6	
Rated current = limiting current		mA	1200	600
Relative duty cycle		%	100	

Further details on request

E1L-controller.

Rectangular solenoid and AMP-connector

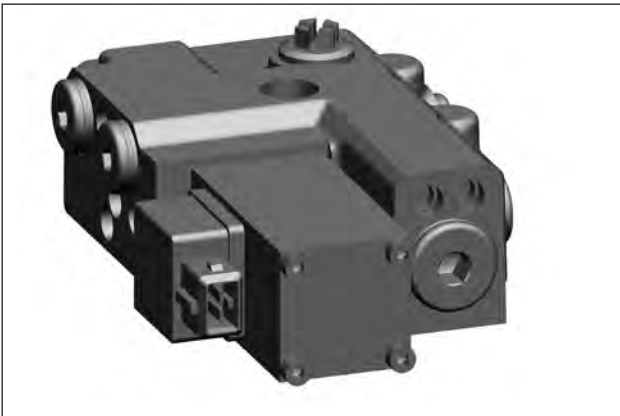

ETP-controller.

Tubular solenoid and AMP-connector

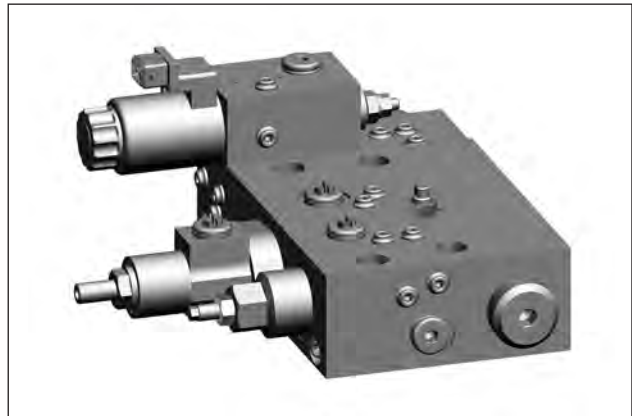

Pump controllers with position feedback

TL2-, LEP- and ETP-controllers offer a feedback of the swashplate position. Therefore they are – unlike LP-, E1L- and H1L-controllers – not mounted on the valve plate housing, but on the pump housing. Besides their individual characteristics, these controllers have some similar features.

P-axis (LEP/ETP): Pressure cut-off characteristic

LEP- and ETP-controllers offer a pressure cut-off (PCO), just like the LP-controller. This prevents the pump pressure exceeding a previously set maximum. The PCO is set to a customer-specific value between 125 bar and 420 bar ex works. Using a control signal at the XD port, the actual response pressure of the PCO valve of LEP- and ETP-controllers can be increased steplessly. The response pressure of the valve is increased by 4.3 bar by every bar increase at the XD port. The maximum pressure of 420 bar must not be exceeded.

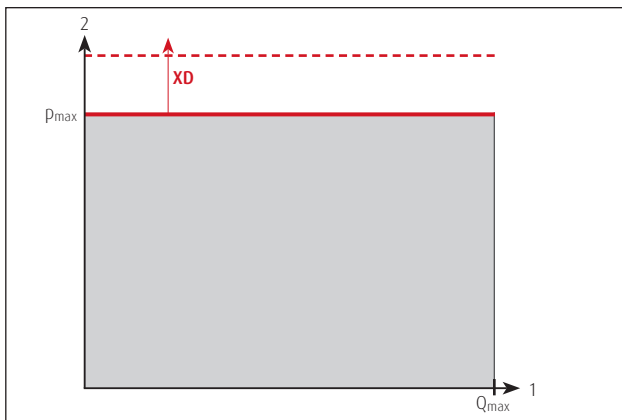

- 1 Displacement volume
- 2 Pressure
- Maximum performance range of the pump
- Pressure cut-off basic setting
- - Characteristic shifting by control signal

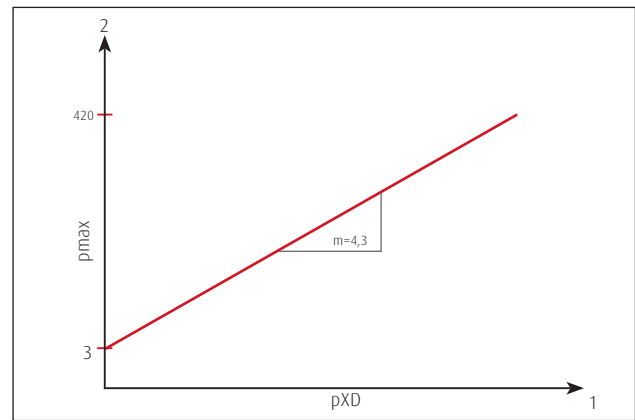

- 1 Control pressure at XD port
- 2 Pressure cut-off response pressure
- 3 Pressure cut-off basic setting

E-Axis (LEP/ETP): Electric flow setting

The swash angle and thus the flow of the pump is set by means of an electric signal with the LEP and ETP controller. The actual current depends on the voltage-level of the application and the nominal size of the pump. Without an electric signal, the pump swashes to minimal displacement.

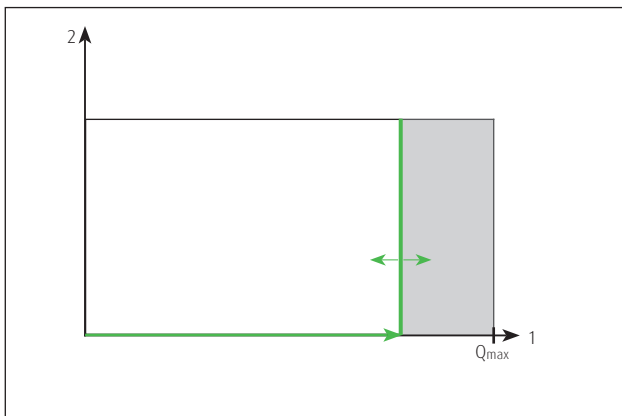

- 1 Displacement
- 2 Pressure
- Maximum performance range of the pump
- Electro-proportional flow setting
- Provided power

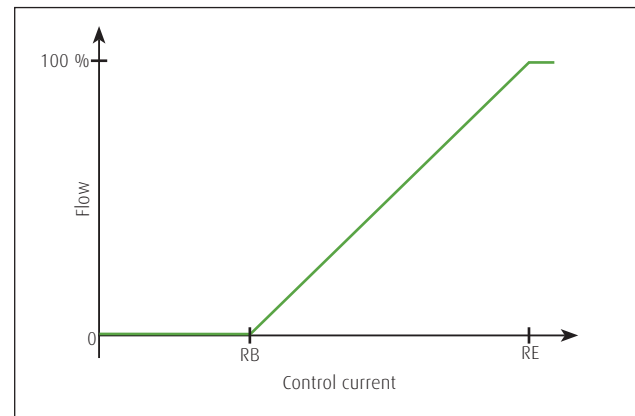

Rated size		Control current	
		12 V	24 V
RB Regulation begin	105,135	464 mA	232 mA
	210	490 mA	245 mA
	280	524 mA	262 mA
RE Regulation end	105 - 280	1200 mA	600 mA

Pump controllers with position feedback

T-Axis (TL2/ETP): hydraulic movement of the regulation begin

Controllers of the TL2 and ETP type offer a power limitation with a hyperbolic characteristic. The controller is set ex works to a customer specific power limit value. The volume flow is restricted, when this limit is exceeded. By means of control ports at the controller, the point at which the power limiter sets in can be raised, as well as lowered during operation.

Dependent on the rated size of the unit, there is a minimum value for the power limitation which must not be underrun, neither by the ex work setting, nor by shifting. The maximum mechanically set value at which the power limitation sets in, is 250 bar, independent of the pump's rated size and speed. The pump must never be operated with more than its maximum power.

Power limiter characteristic curve

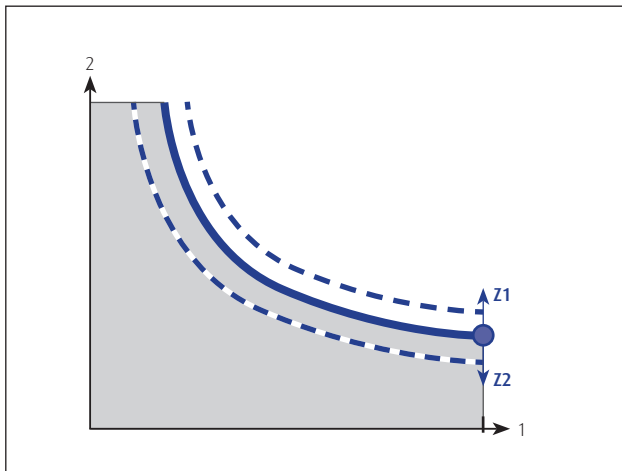

- 1 Displacement
- 2 Pressure
- Power range of the pump
- Regulation begin power limitation

Shifting of the regulation begin

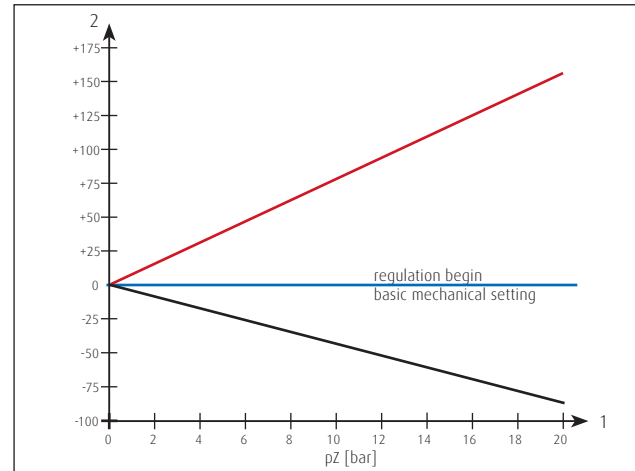

- 1 Pilot pressure port Z1, Z2
- 2 Displacement of the regulation begin [bar]
- Pilot pressure port Z1
- Pilot pressure port Z2

Power limiter performance

	Rated size					
	75	105	135	210	280	
Ex works setting [kW]	6 - 82	9 - 106	12 - 136	24 - 184	32 - 221	
Shifting of the regulation begin [bar/bar]	Z1	7.1	7.1	7.1	7.4	7.8
	Z2	-3.2	-3.2	-3.2	-3.3	-3.4
Regulation begin minimum [bar]	60	60	60	80	80	
Regulation begin [bar] (mechanically set)	250					
Max. pressure at Z1/Z2 [bar]	25					

Controllers. LEP. Load Sensing with electro-proportional flow limitation and pressure cut-off

The HPR with LEP-controller offers an on-demand load sensing flow control. The actual volume flow, delivered by the pump can be restricted by an electrical signal in certain points of operation. A pressure cut-off function protects the hydraulic system from overload.

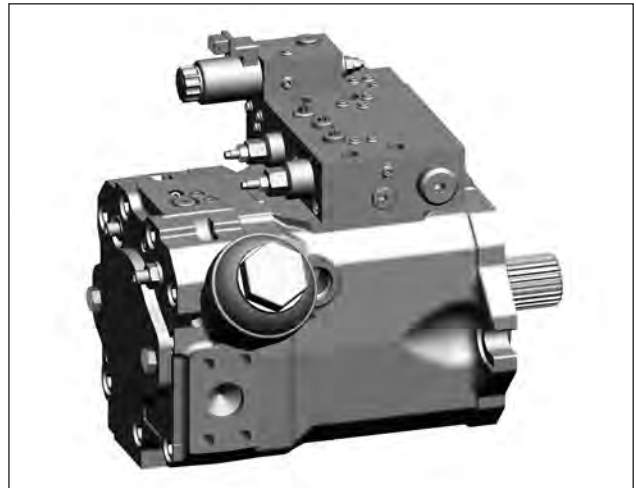
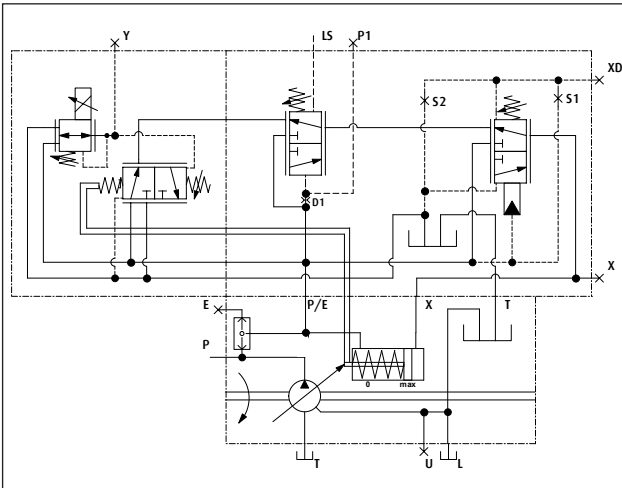

Without any signal at the solenoid or the LS-port, the pump is swashed back to stand-by position. Both signals at the same time are required for the pump to leave stand-by position. The actual swash angle of the pump is determined by the signal with the lower target value.

The responding behaviour of the pressure cut-off can be remote-controlled by a hydraulic signal at the XD port as an option. S1 is then equipped with an orifice and S2 is sealed. If only the mechanical preset of the PCO is used, S1 is sealed and S2 is not equipped. Details, see <<Pump controllers with position feedback. P-axis>>

Characteristic LEP controller

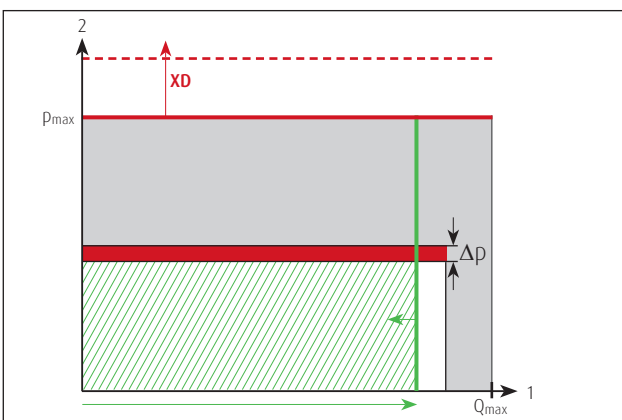

- 1 Flow
- 2 Pressure
- Maximum performance range of the pump
- Actual power demand of the system
- Regulating Δp
- Provided power
- Pressure cut-off basic setting
- - Characteristic shifting by control signal
- Electro-proportional flow setting

LEP-controller

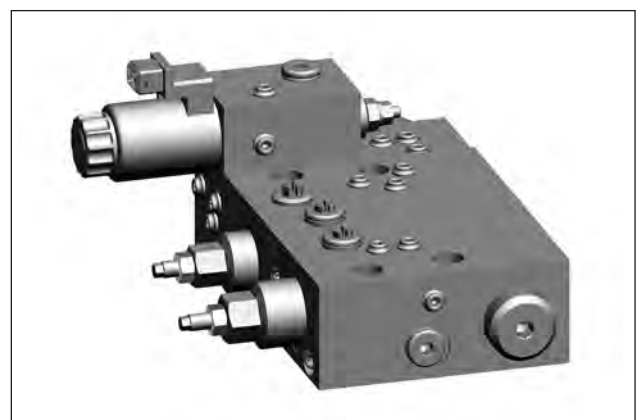

Controllers. ETP. Electro-proportional flow setting, power limitation and pressure cut-off

The HPR with ETP-controller delivers a volume flow which is exactly proportional to the electric control signal. Superposed, the controller offers a hyperbolic power limitation, which optimally exploits the power of the prime mover and also protects it from overload. In addition to this, a pressure cut-off protects the hydraulic system. The controller is supplied via a feed port "E" at the port plate housing.

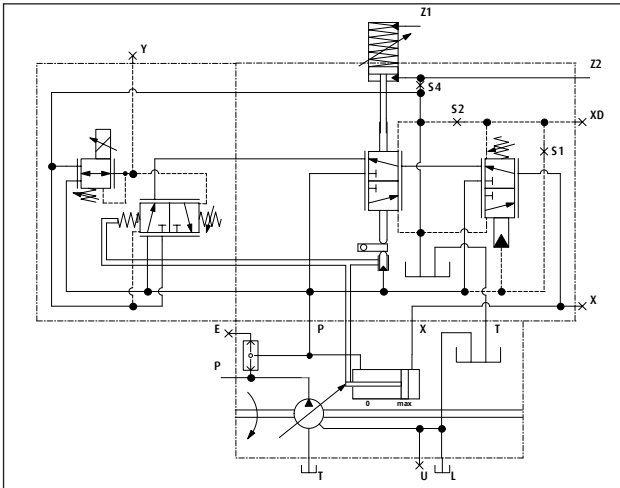

The ETP-controller offers a so called hydraulic power mode function. This means, that the regulation begin of the power limitation can be shifted from its mechanical basic setting by means of a remote control port Z1/Z2 at the controller. If the regulation begin is intended to be below the basic setting, which means that the pump performance is reduced, then the port Z2 is used, S4 is closed. If the mode function is not used at all, or only with the Z1 port, S4 is equipped with an orifice. Z2 is then sealed pressure tight. For details, see <<Pump controllers with position feedback. T-axis>>

The responding behaviour of the pressure cut-off can be remote-controlled by an hydraulic signal at the XD port as an option. S1 is then equipped with an orifice and S2 is sealed. If only the mechanical preset of the PCO is used, S1 is sealed and S2 is not equipped. Details, see <<Pump controllers with position feedback. P-axis>>

Characteristic ETP-controller

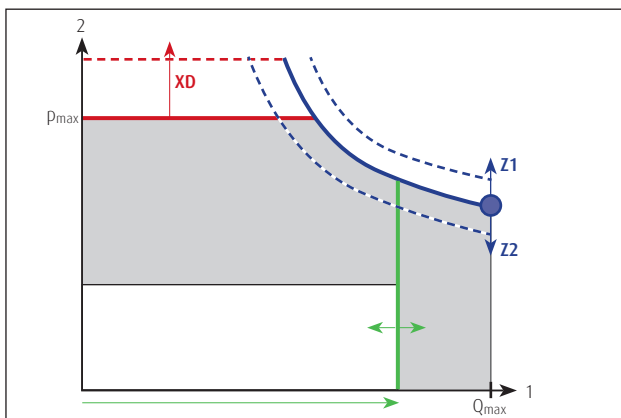

- 1 Displacement
- 2 Pressure
- Maximum performance range of the pump
- Electro-proportional flow setting
- Provided power
- Regulation begin power limitation
- Pressure cut-off basic setting
- - Characteristic shifting by control signal
- Pressure cut-off basic setting
- - Characteristic shifting by control signal

ETP Regler

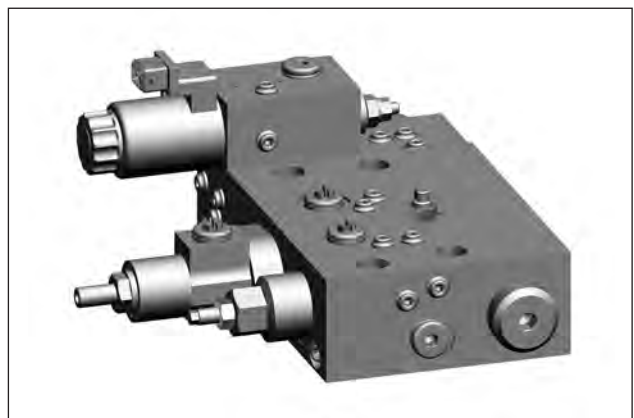

Dimensions. LP-controller

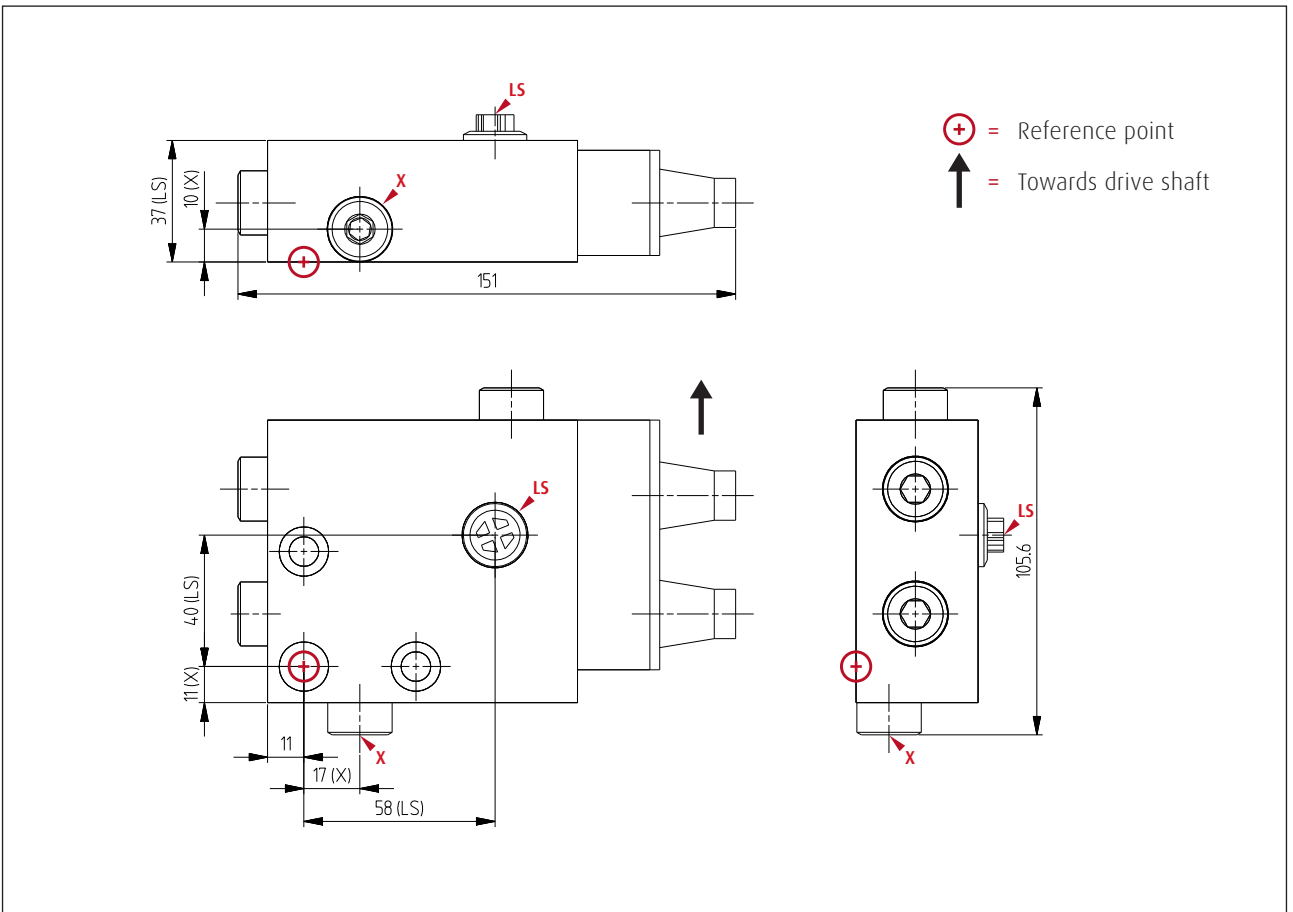
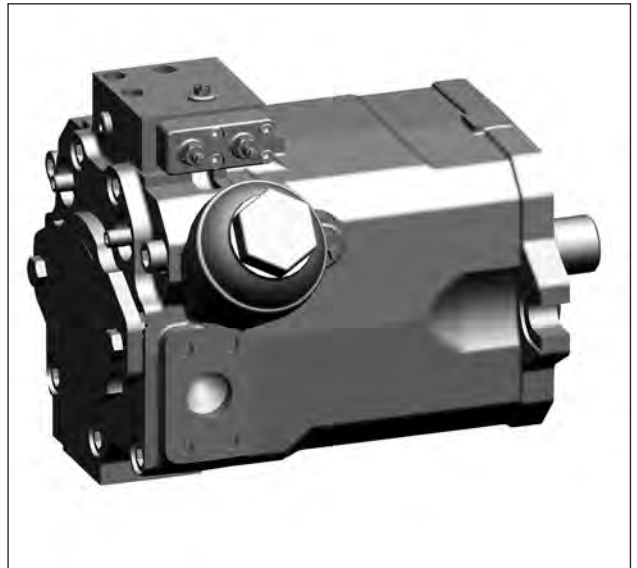
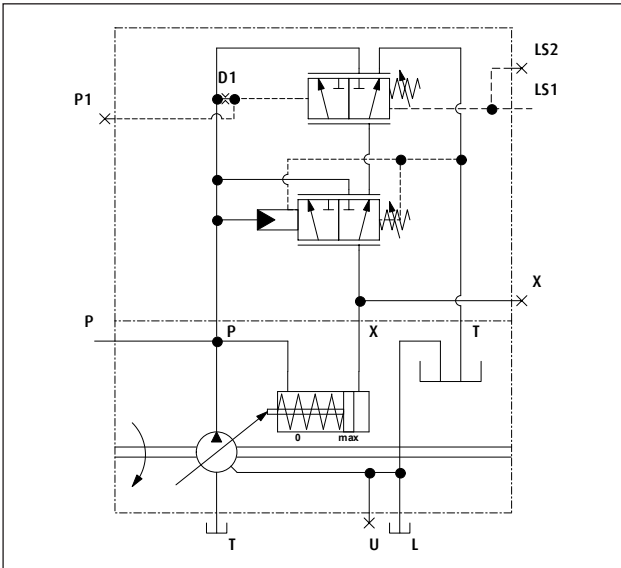

Dimensions:	approx. 151 x 105.6 x 37 mm	
Connections:	X	Test port actuating pressure M14x1.5
	LS1, 2	Load sensing signal / test port M14x1.5
	P1	Test port pump pressure M14x1.5

Dimensions. H1L-controller

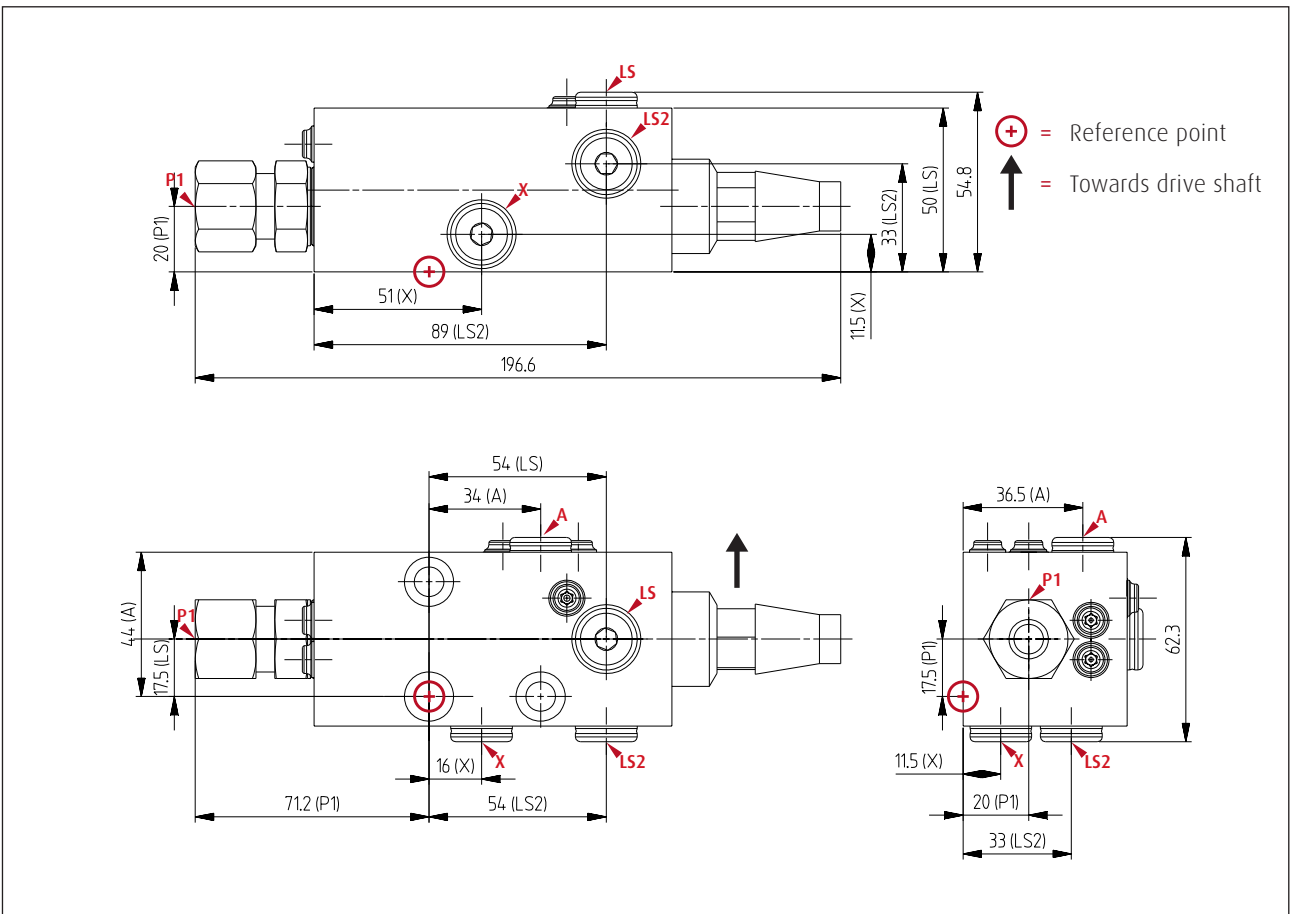
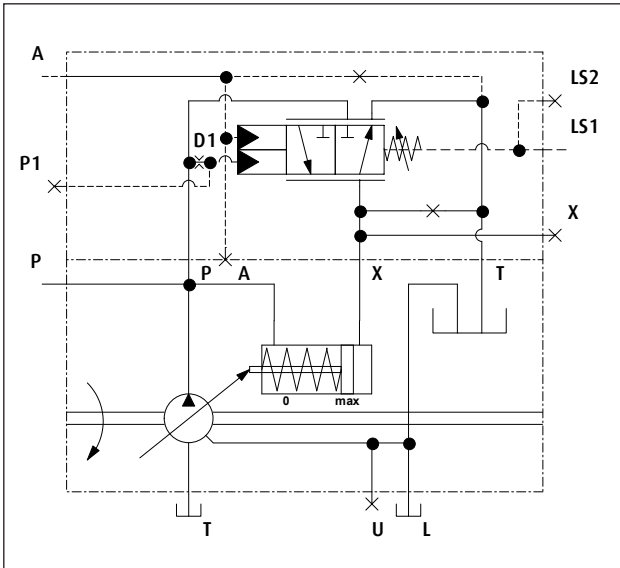

Dimensions:	approx. 196.6 x 62.3 x 54.8 mm	
Connections:	A	Test port control pressure M14x1.5
	X	Test port actuating pressure M14x1.5
	LS/LS2	Load sensing signal / test port M14x1.5
	P1	Test port pump pressure 12 S (ISO 8434-1)

Dimensions. E1L-controller

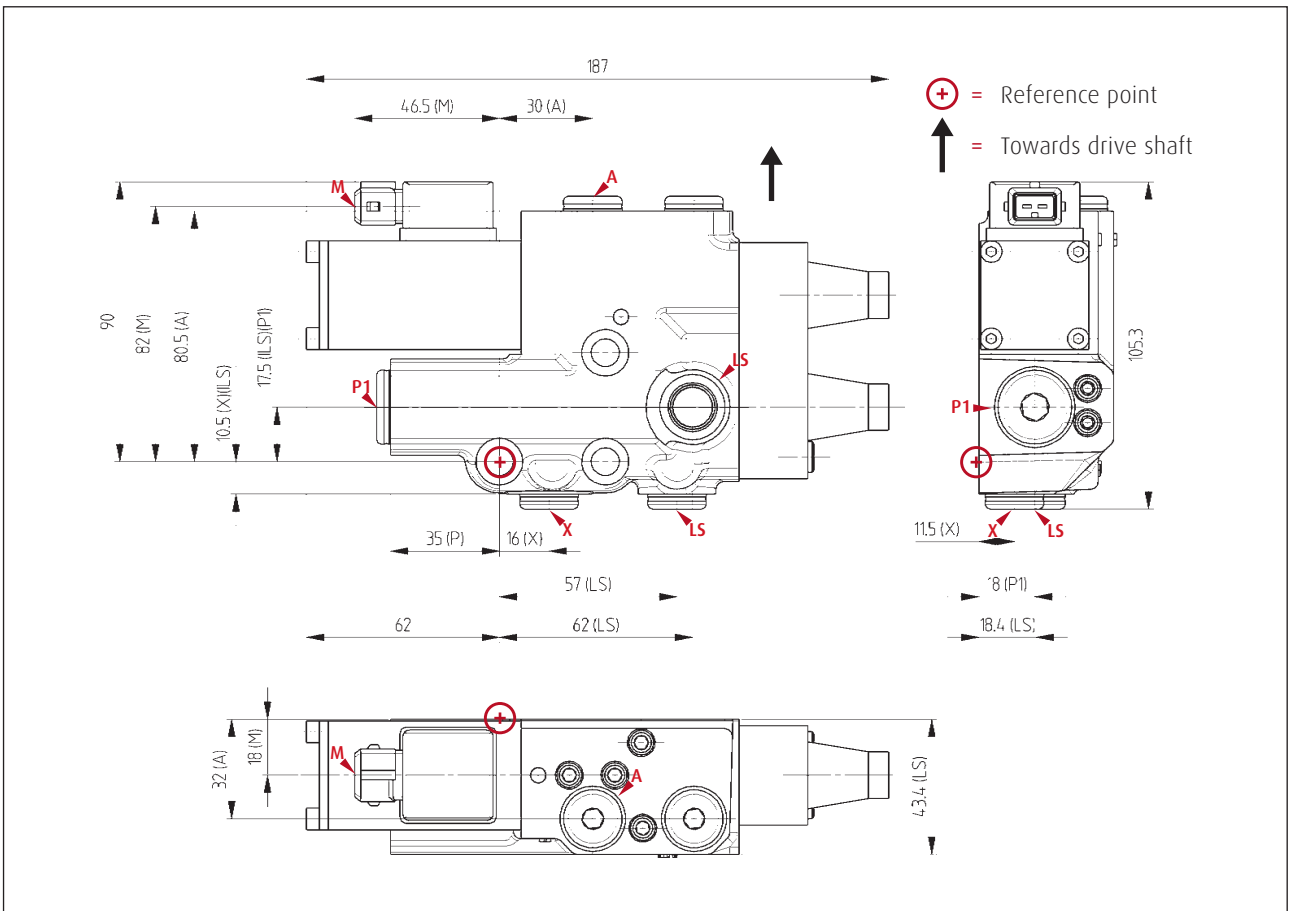
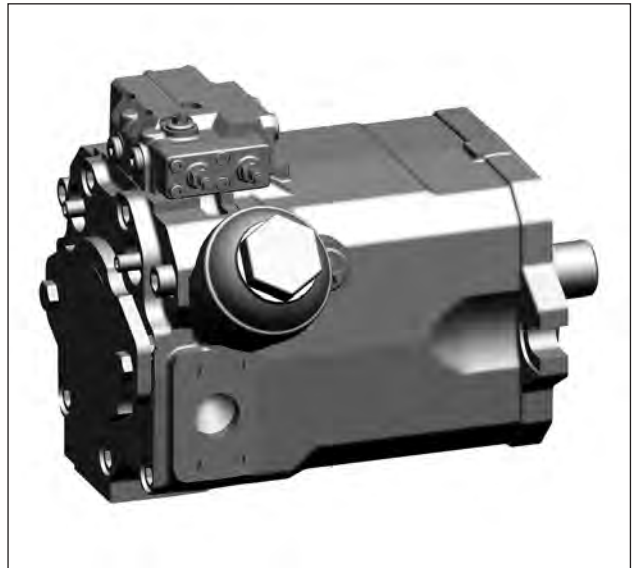
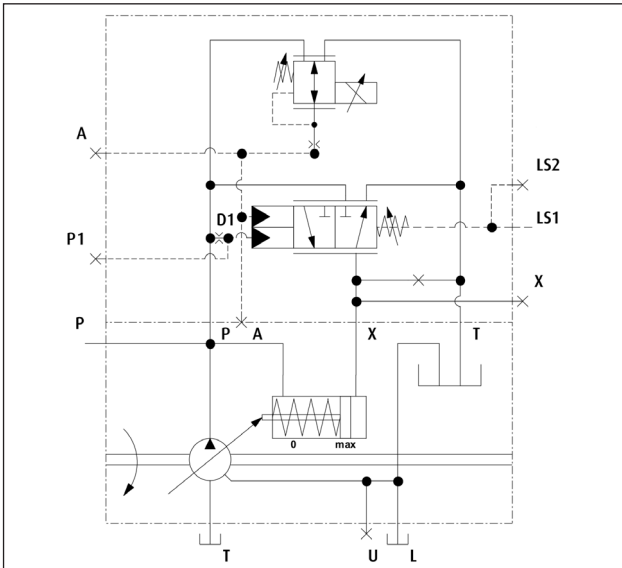

- Dimensions: approx. 187 x 105.3 x 43.4 mm
- Connections:
- | | | |
|-------|---|---------|
| A | Test port control pressure | M14x1.5 |
| X | Test port actuating pressure | M14x1.5 |
| LS1,2 | Load sensing signal / test port | M14x1.5 |
| P1 | Test port pump pressure | M18x1.5 |
| M | Solenoid with AMP-JPT connector (example) | |
- Further information, see <<Controllers. Electrical properties>>

Dimensions. TL2-controller

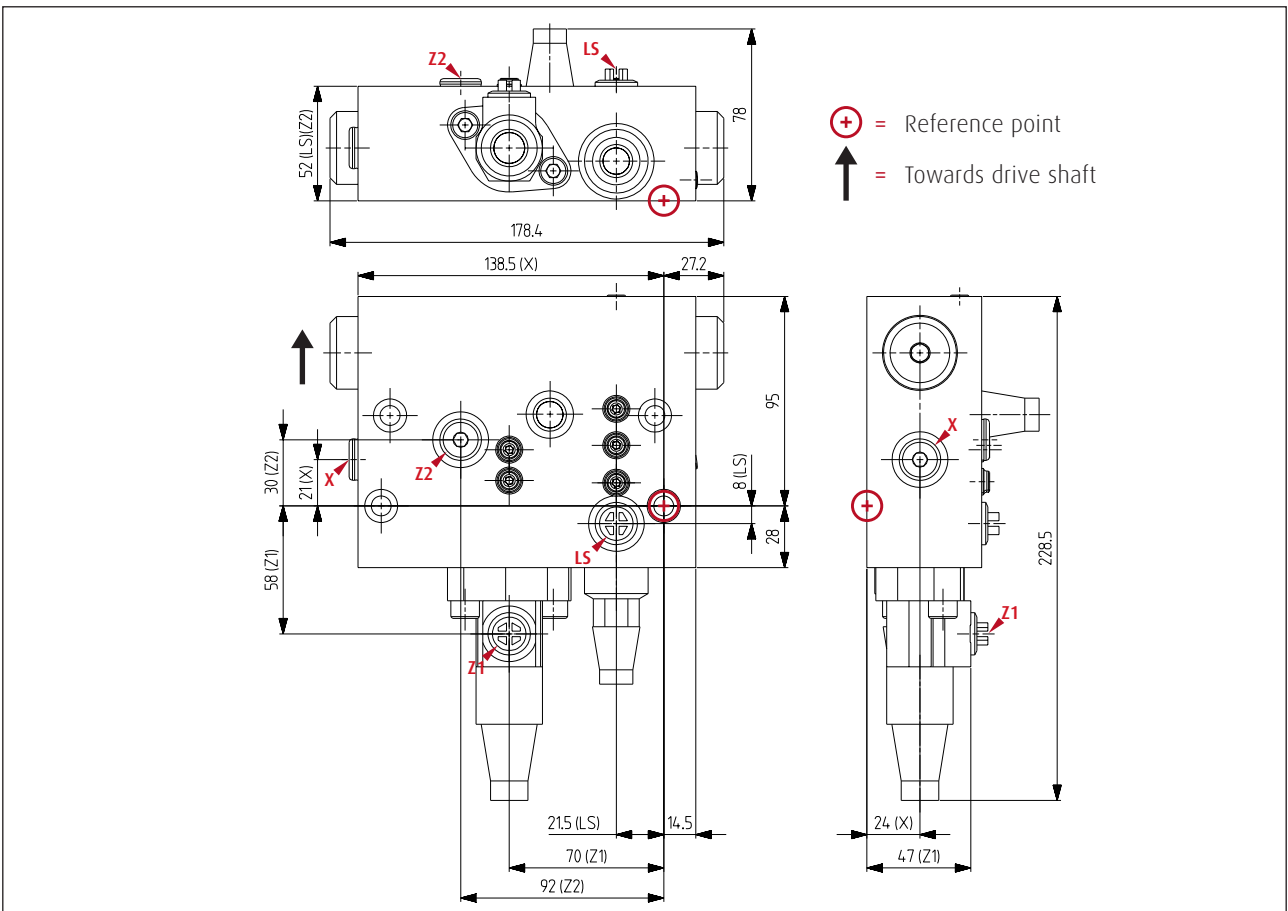
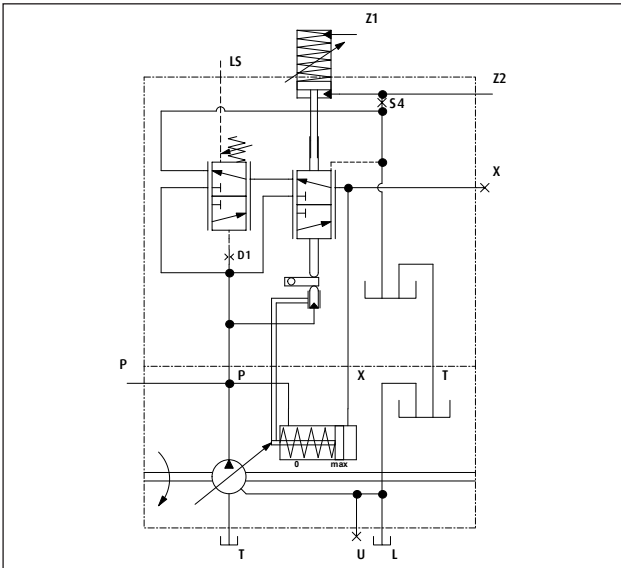

Dimensions:	approx. 178.4 x 228.5 x 78 mm	
Connections:	X Test port actuating pressure	M14x1.5
	LS Load sensing signal	M14x1.5
	Z1/Z2 Remote control for power limitation	M14x1.5

Dimensions. LEP-controller

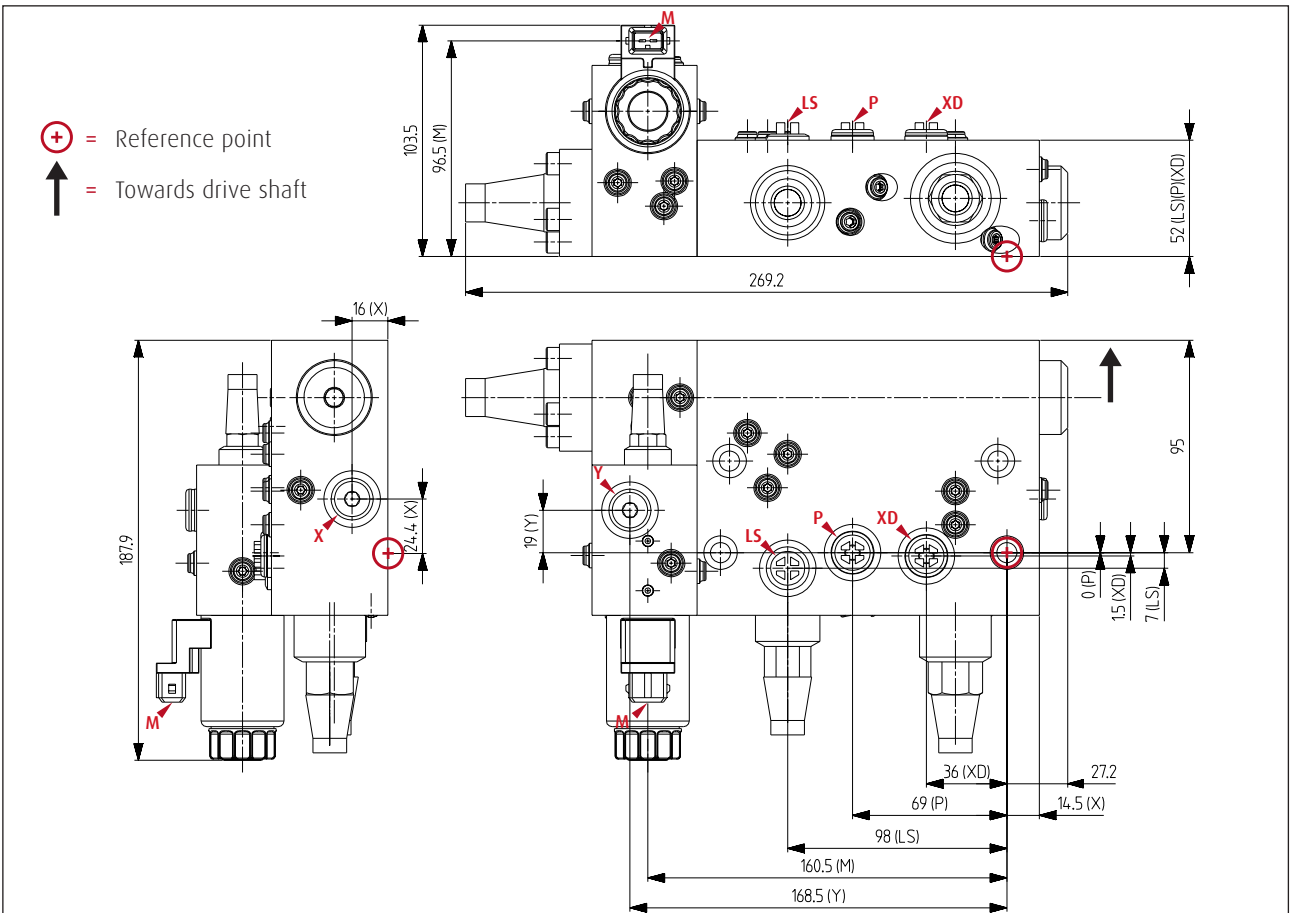
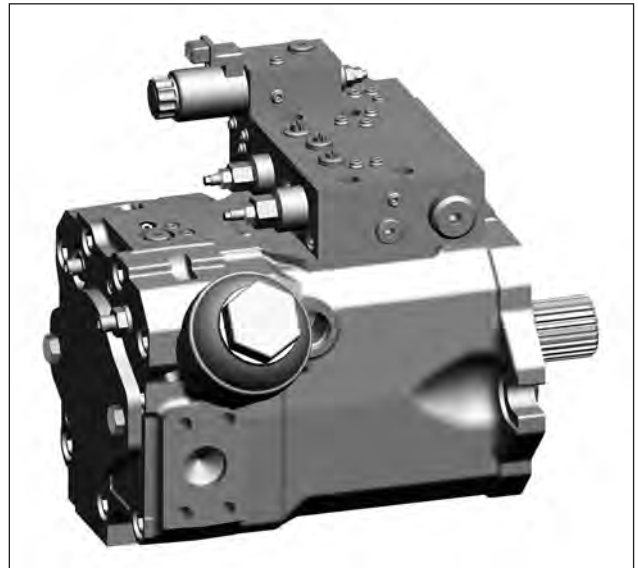
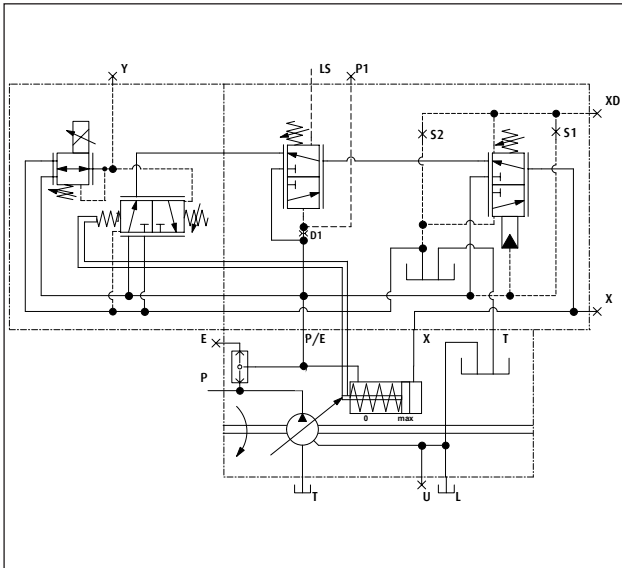

Dimensions:	approx. 269.2 x 187.9 x 103.5 mm	
Connections:	X	Test port actuating pressure M14x1.5
	Y	Test port pressure-reducing valve M14x1.5
	XD	Port for external pressure cut-off M14x1.5
	LS	Load sensing signal M14x1.5
	P	Test port pump pressure M14x1.5
	M	Solenoid with AMP-JPT connector (example)
	Further information, see <<Controllers. Electrical properties>>	

Dimensions. ETP-controller

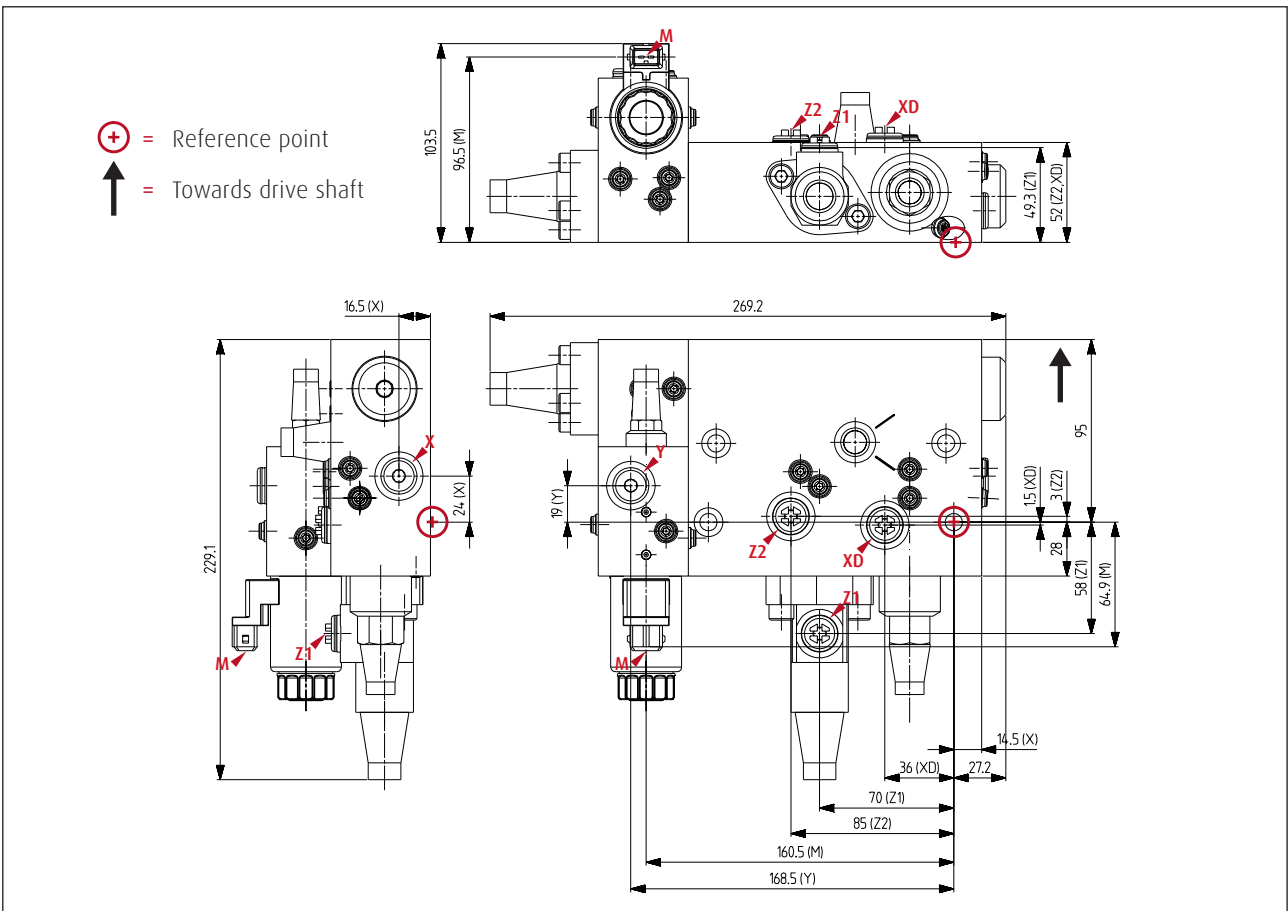
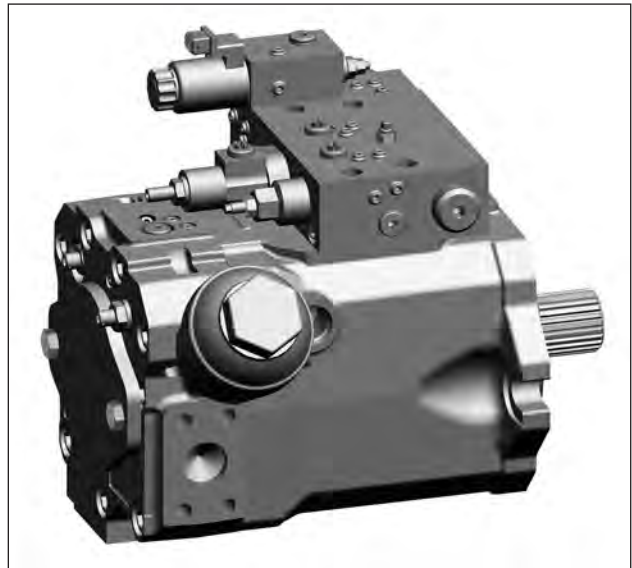
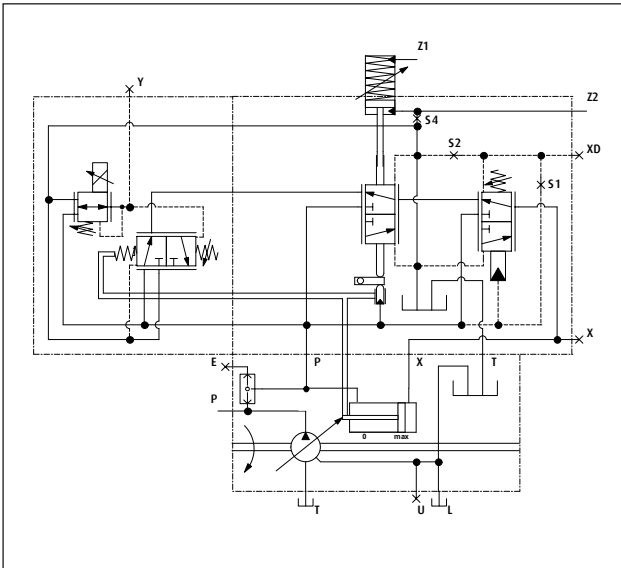

Dimensions:	approx. 269.2 x 229.1 x 103.5 mm	
Connections:	X	Test port set pressure M14x1.5
	Y	Test port actuating pressure M14x1.5
	XD	Connection for external pressure cut-off M14x1.5
	Z1/Z2	Remote control for power limitation M14x1.5
	M	Solenoid with AMP-JPT connector (example)
	Further information, see <<Controllers. Electrical properties>>	

Dimensions. Single pumps HPR-02 for LP, E1L, H1L

The dimensioning is shown by one exemplary pump configuration. The external dimensions are determined by the individual configuration, including the choice of a controller, direction of rotation, optional SPU and the settings of the pump. Further information can be found in the specific sections of this datasheet, in particular the sections <<Torque transmission. Mounting flange>> and <<Torque transmission. Drive shaft>>.

Dimensions of the pump without controller

Rated size	55	75	105	135	165	210	280
D	127	127	127	152.4	152.4	165.1	224
L1	220.3	231.8	262	284.5	333.1	348	403
L2	259.3	270.8	301	323.5	372.1	387	442
L3	207.3	220.3	241	263.5	317.1	333	375
H1	100	102	103.5	111.5	128.5	134.5	152
H2	146	146	136	145.5	152.4	143.5	238
B1	111	190.3	199.6	216	251.5	268	306.1
B2	208	208	207	256	269	268.8	314.5
B3	120	111	122	129	128.9	126.5	125.1
B4	21	21	21	21	19	21	21

Ports

Rated size	55	75	105	135	165	210	280
P	¾"	¾"	1"	1 ¼"	1 ¼"	1 ½"	1 ½"
P(L)	182.8	194.3	218	243.5	283.1	295	344.5
P(H)	23.5	23.5	26	30	43	27	46
P(B)	91	90.5	100	107	134.5	134.5	149.5
T	1 ½"	1 ½"	2"	2"	2 ½"	3"	3 ½"
T(L)	189.8	201.3	227	249.5	285.6	298	344.5
T(H)	94	94	103.5	120	119	149	167
T(B)	21	21	25	30	0	57	57
L/U	M22x1.5	M22x1.5	M22x1.5	M27x2	M27x2	M27x2	M33x2
L(L)	112.8	124.3	142	164	180.6	197.5	215.5
L(H)	52	52	53	61	65	71.5	80.5
L(B)	86.5	86.5	85	101.5	108	128	145
U(L)	72	72	72	74.5	81.1	83	109
U(H)	44	44	54	54	62	60	68
U(B)	78.5	78.5	92.5	92.5	101	118	129.5

Dimensions. Single pumps HPR-02 for LP, E1L, H1L

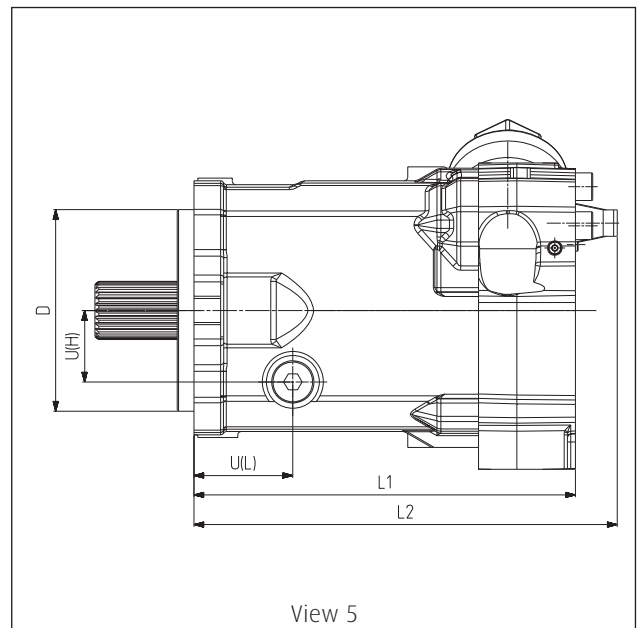
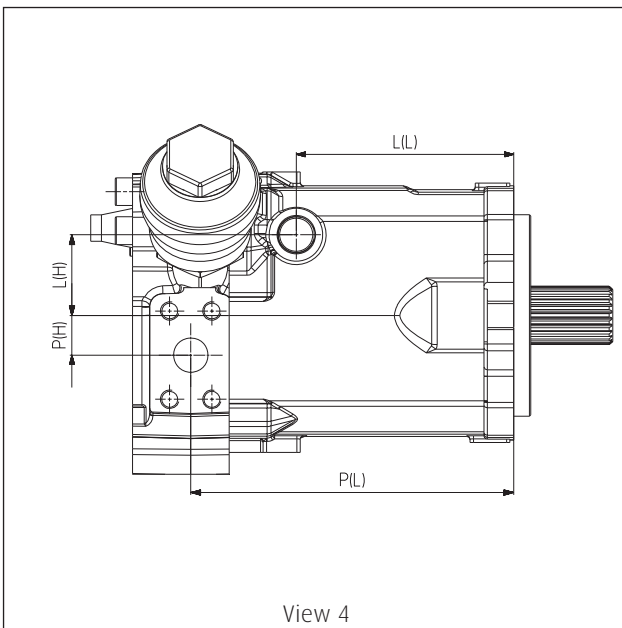
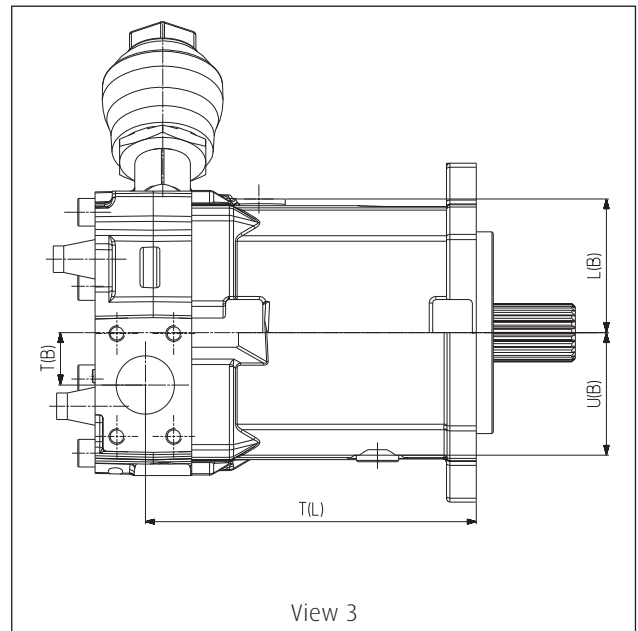
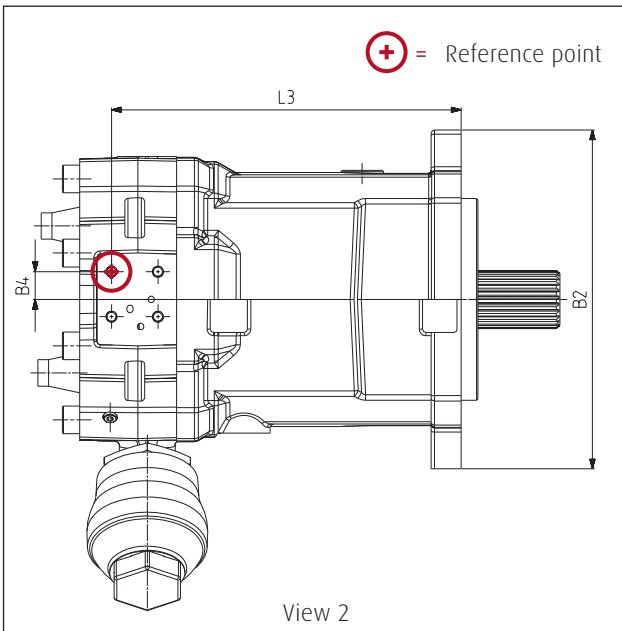
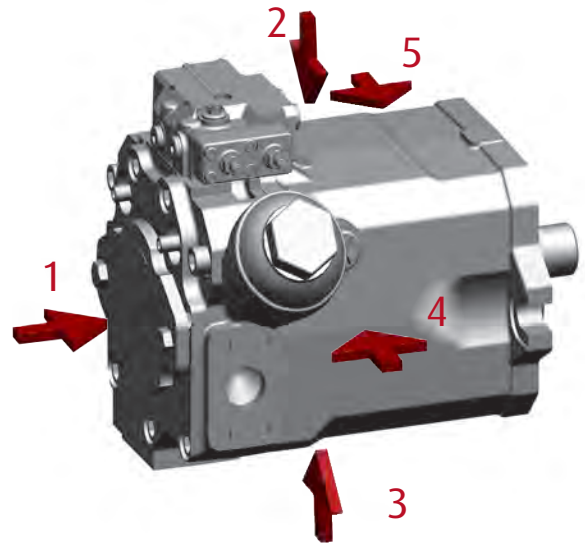
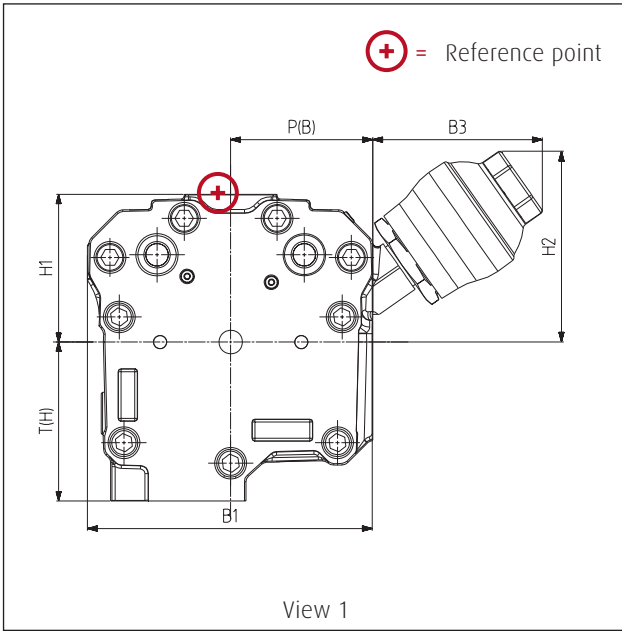

Dimensions. Single pumps HPR-02 for TL2, LEP, ETP

The dimensioning is shown with one exemplary pump configuration. The external dimensions are determined by the individual configuration, including the choice of a controller, direction of rotation, optional SPU and the settings of the pump. Further information can be found in the specific sections of this datasheet, in particular the sections <<Torque transmission. Mounting flange>> and <<Torque transmission. Drive shaft>>.

Dimensions of the pump without controller

Rated size	105	105	135	210	280	280
In accordance with ISO 3019	-1	-2	-1	-1	-1	-2
D	127	125	125.4	165.1	165	224
L1	262	272	284.5	348	403	403
L2	301	311	323.5	387	442	442
L3	108.9	118.5	82.8	138.5	168	168
H1	104.5	104.5	111.5	134.5	152	152
H2	134	134	144	144.3	200.7	238
H3	104.5	104.5	104	135	135	144.5
B1	194.5	194.5	214.8	266.3	314.5	314.5
B2	208	208	256.5	269	272	272
B3	118	116	106.7	102.4	119.5	120.2
B4	64	64	64	64	82.5	82.5

Ports

P	1"	1"	1 ¼"	1 ½"	1 ½"	1 ½"
P(L)	218	228	243.5	295	344.5	344.5
P(H)	26	26	30	27	46	46
P(B)	100	100	107	144.5	154.1	155.5
T	2"	2"	2"	3"	3 ½"	3 ½"
T(L)	227	237	249.5	298	344.5	344.5
T(H)	104	104	120	149	167	167
T(B)	25	25	39.5	27	44	57
L/U	M22x1.5	M22x1.5	M27x2	M27x2	M33x2	M33x2
L(L)	142	152	164	191	215.5	215.5
L(H)	53	53	61	97.5	80.5	80.5
L(B)	92.5	92.5	101	128	129.5	144.9
U(L)	72	82	74.5	83	109	109
U(H)	54	54	54	60	68	68
U(B)	85	85	92	118	159.5	131.3
E*	M14x1.5	M14x1.5	M14x1.5	M14x1.5	M14x1.5	M14x1.5
E(L)	240.8	250.8	249.5	303	375	346
E(H)	135.6	135.6	142.6	165.6	183.1	183.1
E(B)	15	15	16	20	20	20

*) ETP-controller only: External supply pressure

Dimensions. Single pumps HPR-02 for TL2, LEP, ETP

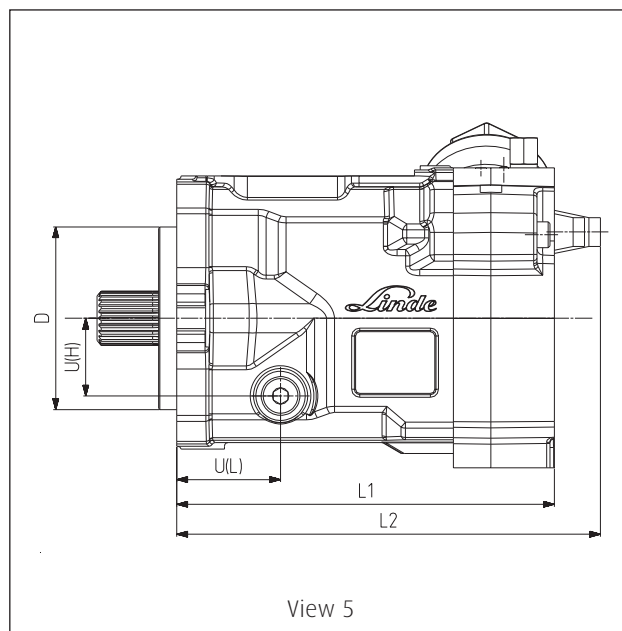
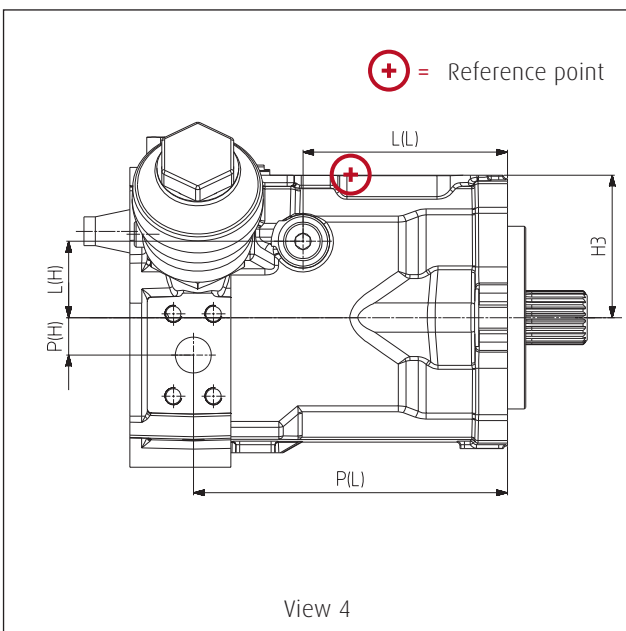
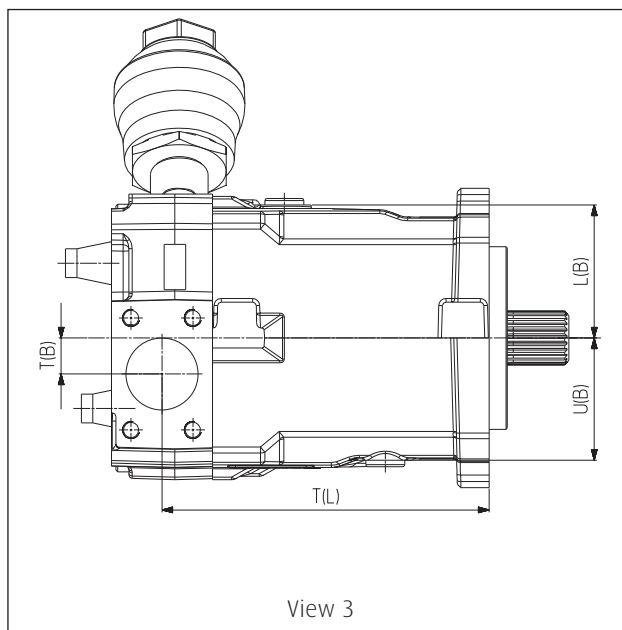
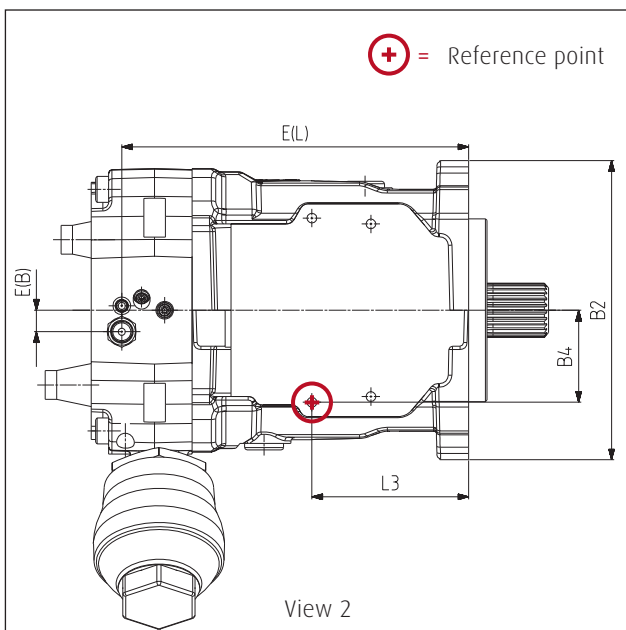
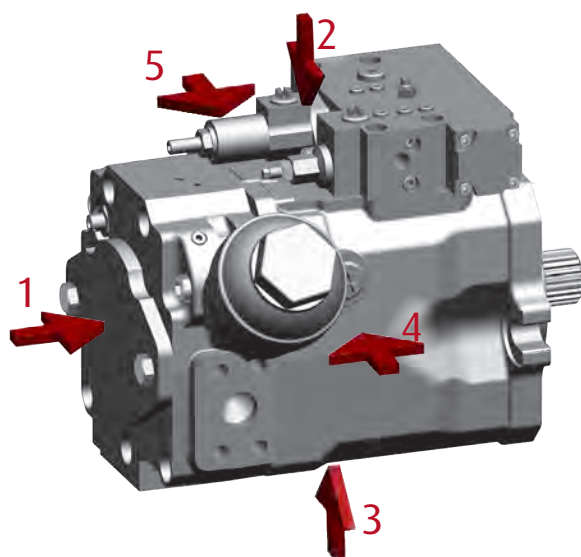
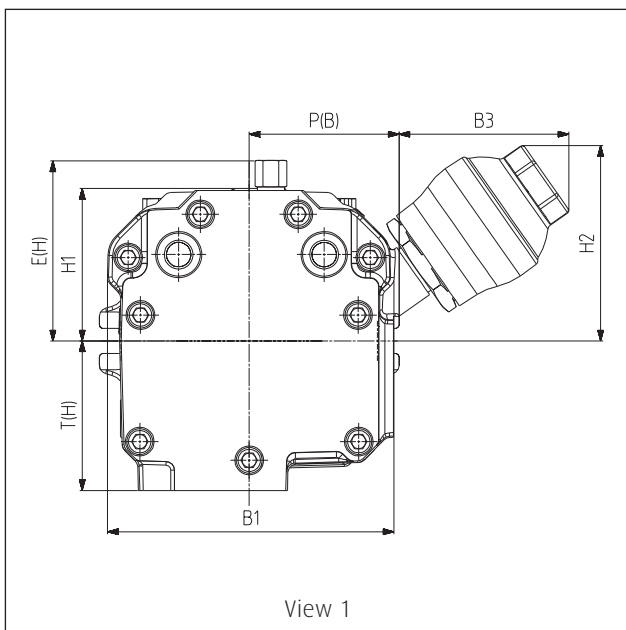

Dimensions. Double pumps and plug-in pumps

Double pumps consist of two HPR rotating groups, arranged back-to-back to a common port plate housing, sharing one common suction port. They are thus more compact than two standard pumps in a tandem configuration. Compared to a pump of equal rated size with a single rotating group, double pumps offer higher speed and more narrow radial dimensions. They also provide a PTO option. The position of the ports, controllers and SPU differs from the previously shown pumps.

Further details on request.

Rated size	105D	105D	105D	165D	165D
Circuit	Single circuit pump			Single or dual circuit pump	
Flange	SAE C with 4 additional bolt holes	plug-in version	SAE 3 / SAE 4	SAE D with 4 additional bolt holes	SAE 3
D1 [mm]	127	216	SAE J617a	152.4	SAE J617a
D2 [mm]	-	-		-	
D3 [mm]	-	-		-	
B1 [mm]	124	124	124	147	147
B2 [mm]	120	120	120	136	136
B4 [mm]	-	222	222	162.3	162.3
H1 [mm]	107	141	141	116	116
H2 [mm]	107	141	141	116	116
H3 [mm] (105:LP, 165 E1L)	138	144	144	170	170
H4 [mm]	-	137	137	255	255
H5 [mm] port P	75	75	75	80	80
H6 [mm] port T	38	38	38	0	0
H7 [mm]	195	196	196	260	260
L1 [mm]	474	358	450	587.6	587.6
L2 [mm]	478	376	468	601	625
L3 [mm]	61.3	171	79	74.6	50.1
L4 [mm]	232	116	208	286.1	310.6
P (SAE)	2 x 1"	2 x 1"	2 x 1"	2 x 1 1/4"	2 x 1 1/4"
T (SAE)	1 x 3"	1 x 3"	1 x 3"	1 x 4"	1 x 4"
L	M22x1.5	M22x1.5	M22x1.5	M27x2	M27x2
U	M22x1.5	M22x1.5	M22x1.5	M27x2	M27x2

Double pump with SAE J744 flange

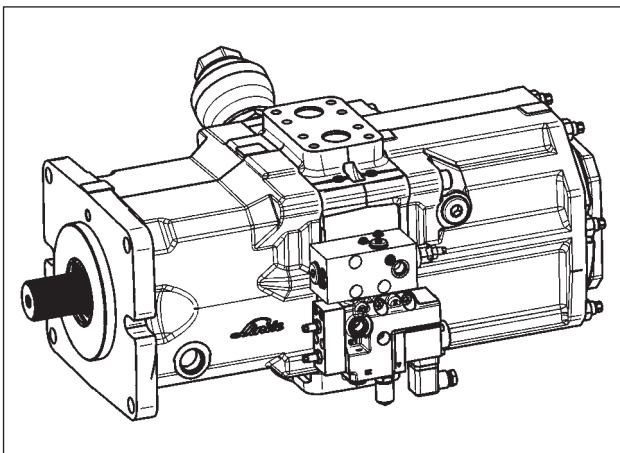

Double pump with SAE J617a flange

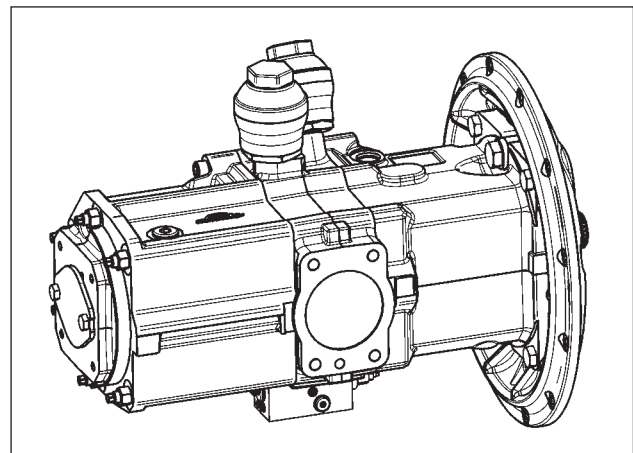

Dimensions. Double pumps and plug-in pumps

Plug-in flange

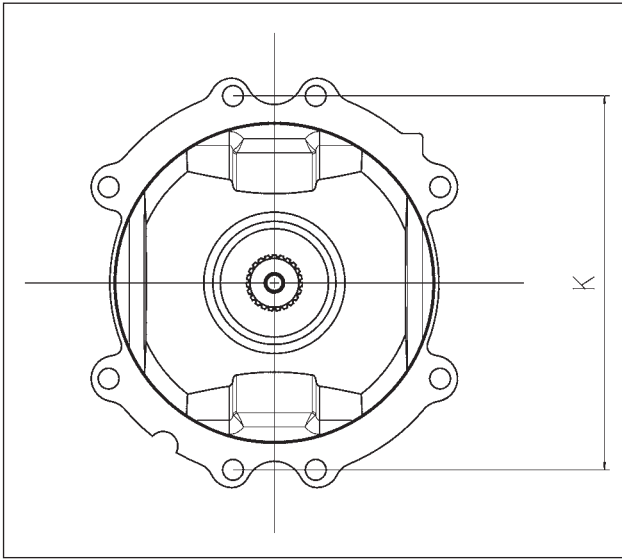

SAE bell housing

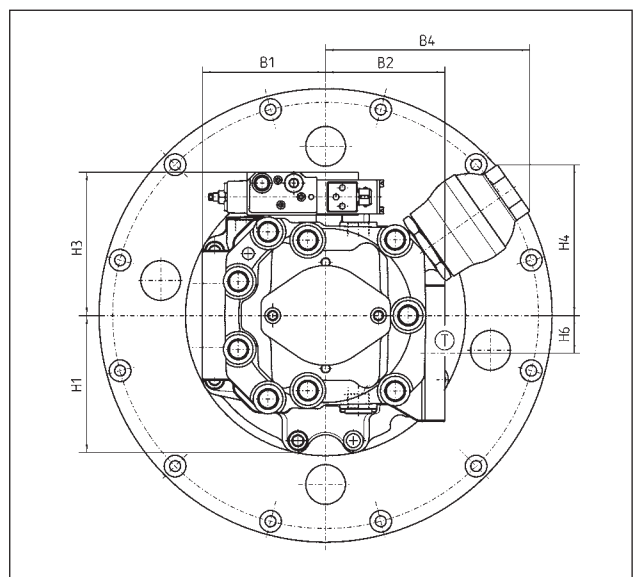
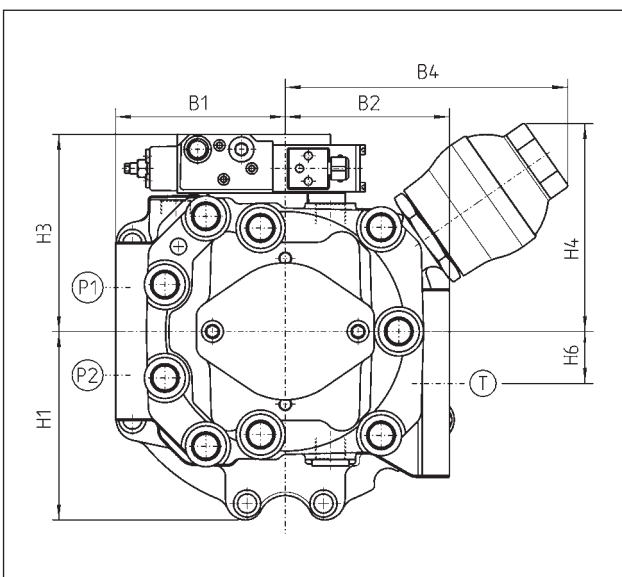
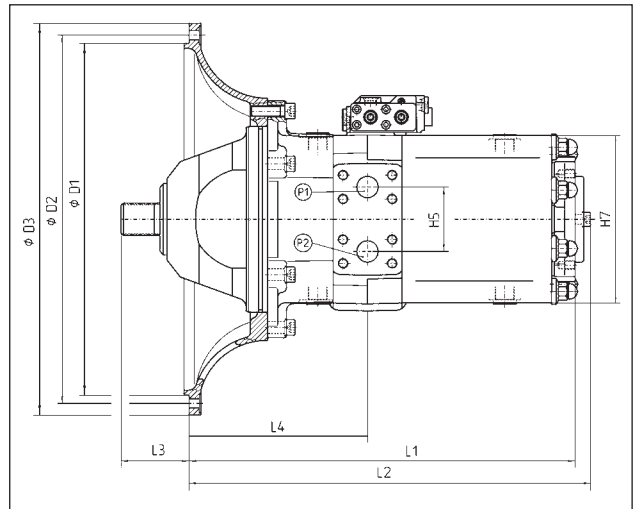
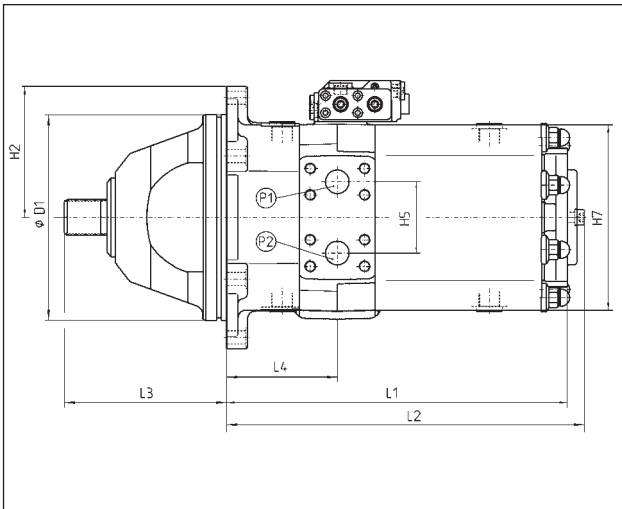
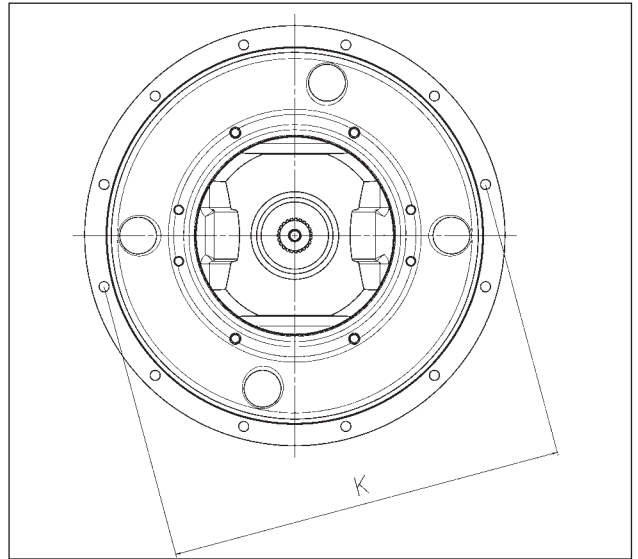

Dimensions. Multiple pumps

Multiple pumps are created by connecting individual pump units in series, with the pumps arranged by capacity. Positioning the gear pump(s) at the end of the tandem ensures optimum space utilisation, output allocation and load distribution. The following table is based on the attached gear pump acting as a pilot pressure pump for the control circuit.

Multiple pump HPR-HPR-02

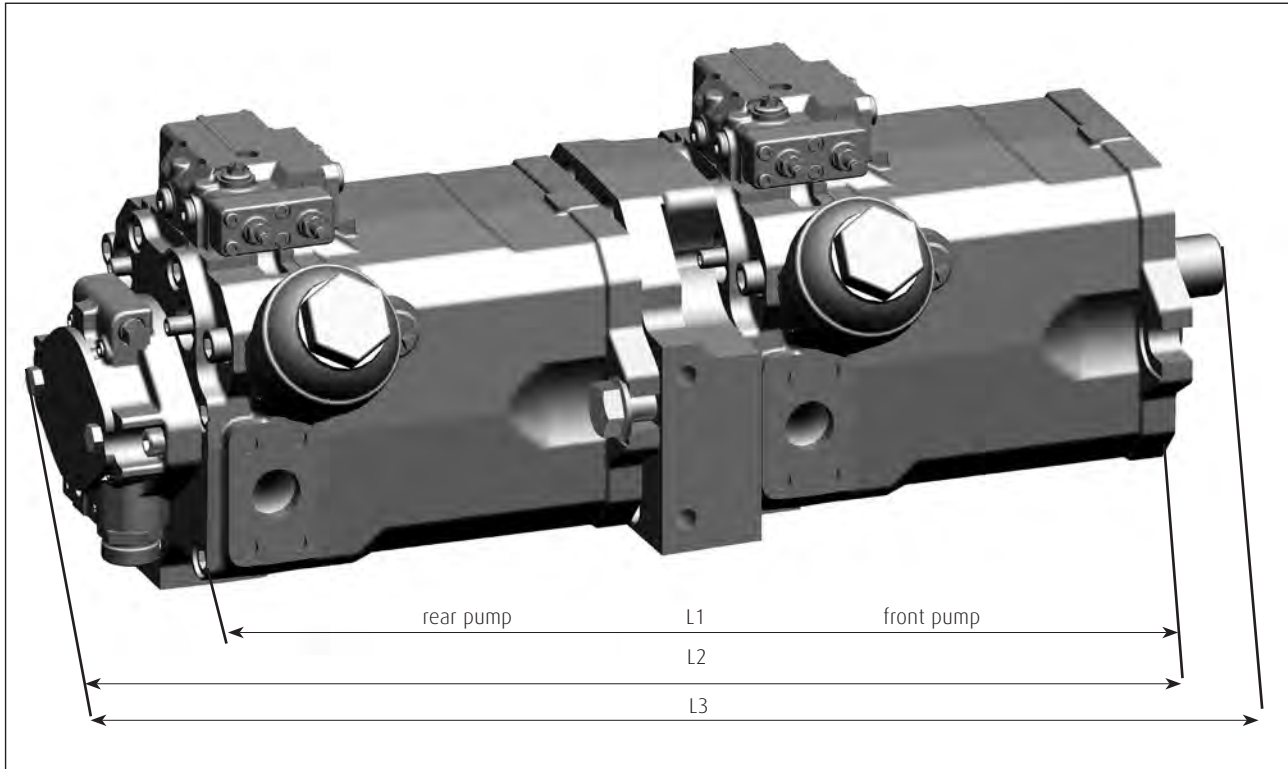

Overall length of multiple pump HPR-HPR-02

Rated size	Rear pump	HPR 55	HPR 75	HPR 105	HPR 135	HPR 165	HPR 210	HPR 280
Front pump	Charge pump	16 cc/rev	22.5 cc/rev	22.5 cc/rev	22.5 cc/rev	38 cc/rev	38 cc/rev	38 cc/rev
HPR 55	L1	488	-	-	-	-	-	-
	L2	548	-	-	-	-	-	-
	L3	602	-	-	-	-	-	-
HPR 75	L1	500	511	-	-	-	-	-
	L2	565	576	-	-	-	-	-
	L3	620	631	-	-	-	-	-
HPR 105	L1	520	531	562	-	-	-	-
	L2	585	596	627	-	-	-	-
	L3	640	651	682	-	-	-	-
HPR 135	L1	536	547	578	619	-	-	-
	L2	596	612	643	684	-	-	-
	L3	671	667	698	759	-	-	-
HPR 165	L1	579	591	621	679	728	-	-
	L2	754	766	796	854	903	-	-
	L3	829	841	871	929	978	-	-
HPR 210	L1	600	612	642	701	749	751	-
	L2	775	787	817	876	924	926	-
	L3	850	862	892	951	999	1001	-
HPR 280	L1	669	680	711	727	775	790	845
	L2	844	855	886	902	950	965	1020
	L3	919	930	961	977	1025	1040	1095

Dimensions. Multiple pumps

Multiple pumps are created by combining individual pump units in series, with the pumps arranged by capacity. Positioning the gear pump(s) at the end of the unit ensures optimum space utilization, output allocation and load distribution. The following table is based on the gear pump acting as boost pump for the HPV-02 variable pump.

Multiple pump HPR-HPV-02

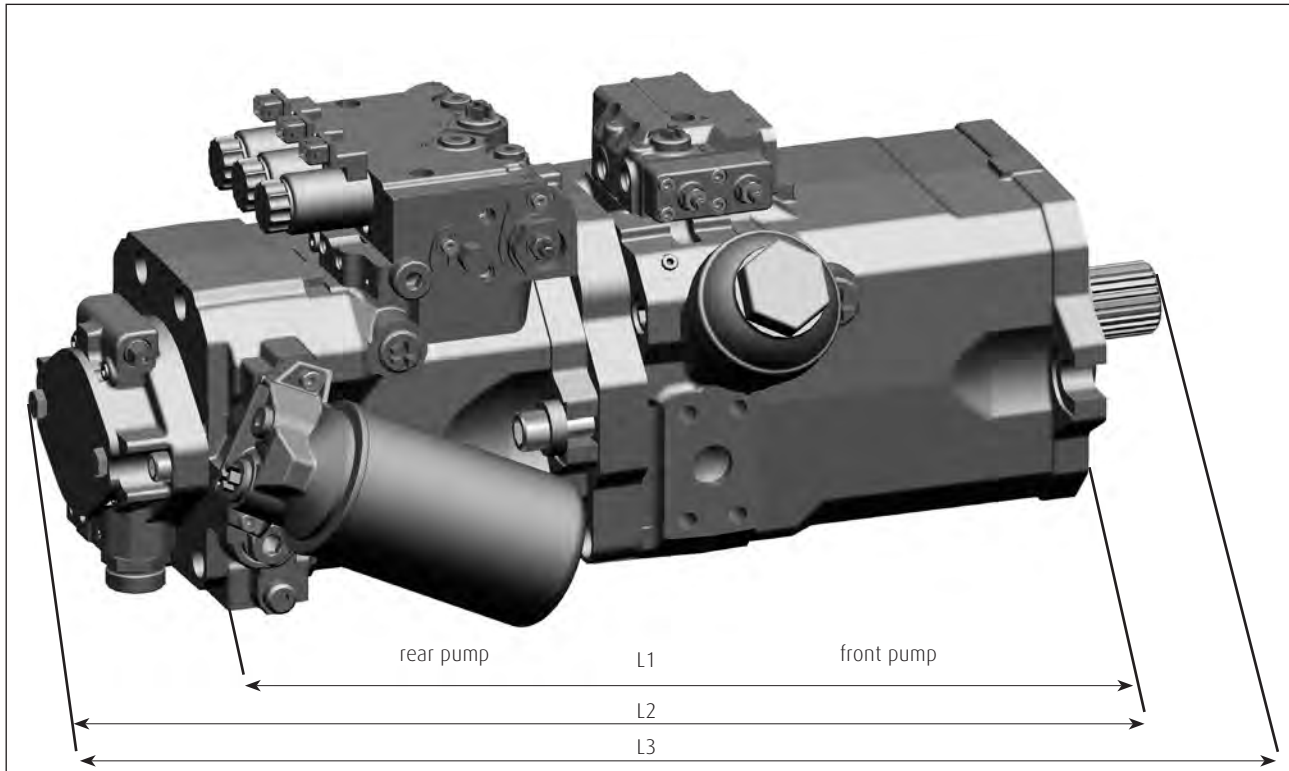

Overall length of multiple pump HPR-HPV-02

Rated size	Rear pump	HPV 55	HPV 75	HPV 105	HPV 135	HPV 165	HPV 210	HPV 280
Front pump	Charge pump	16 cc/rev	22.5 cc/rev	22.5 cc/rev	22.5 cc/rev	38 cc/rev	38 cc/rev	38 cc/rev
HPR 55	L1	493	-	-	-	-	-	-
	L2	553	-	-	-	-	-	-
	L3	607	-	-	-	-	-	-
HPR 75	L1	504	521	-	-	-	-	-
	L2	569	586	-	-	-	-	-
	L3	624	641	-	-	-	-	-
HPR 105	L1	525	542	567	-	-	-	-
	L2	590	607	632	-	-	-	-
	L3	645	662	687	-	-	-	-
HPR 135	L1	541	558	583	623	-	-	-
	L2	601	623	648	688	-	-	-
	L3	676	678	703	763	-	-	-
HPR 165	L1	584	601	626	683	715	-	-
	L2	759	776	801	858	890	-	-
	L3	834	851	876	933	965	-	-
HPR 210	L1	605	622	647	704	736	749	-
	L2	780	797	822	879	911	924	-
	L3	855	872	897	954	986	999	-
HPR 280	L1	674	691	716	730	762	788	834
	L2	849	866	891	905	937	963	1009
	L3	924	941	966	980	1012	1038	1048

Modular system features.

The HPR-02 is based on a modular system with the following characteristics. This enables our distribution partners to configure the product according to your requirements. The latest characteristics and available options can be taken from the model code, which is available on our homepage.

- >> Rated size
- >> V_{max}
- >> Direction of rotation
- >> Pump controller
- >> Solenoid connector type
- >> Solenoid operating voltage
- >> Noise reduction SPU
- >> Port threads
- >> Mounting flange
- >> Drive Shaft
- >> PTO through-drive
- >> PTO attachment
- >> Gear pumps
- >> Gear pump PTO
- >> Pump settings like speed, LS-setting, pressure cut-off, power-limitation
- >> Pressure cut-off remote control
- >> Power limitation remote control
- >> Surface treatment
- >> Name plate



Product Catalogue

- >> Turning Power into Motion

Brochures

- >> Drive systems for construction machines.
- >> Drive systems for agricultural machines.

Datasheets

- >> Model Code. Configuration of the series 02
- >> HMF/A/V/R-02. Hydraulic motors for closed and open loop operation
- >> HPR-02. Self-regulating pumps for open loop operation
- >> HPV-02. Variable pumps for closed loop operation
- >> VT modular. Modular system for LSC manifold valve plate
- >> Linde pressure definitions. According to DIN 24312
- >> Mineral-oil-based hydraulic fluids

How to reach us:



METAU SERVICE S.R.L.
Via Cadriano, 8 - Fr. Cadriano - 40057 Granarolo dell'Emilia (Bo)
Tel.+39051.766422 - Fax +39051.765339 - E-MAIL info@metauservice.it
P.IVA/CODICE FISCALE 02217471206

Metauservice2020

www.metauservice.it

Ref.: Ing. Paolo Bordonaro p.bordonaro@metauservice.it
info@metauservice.it



Linde Hydraulics GmbH & Co. KG, Wailandtstraße 13, 63741 Aschaffenburg
Phone +49 6021 150 00, Fax +49 6021 150 11570, www.linde-hydraulics.com

Turning Power into Motion.

